

## AP Physics-1 summer assignment

Name \_\_\_\_\_

1.

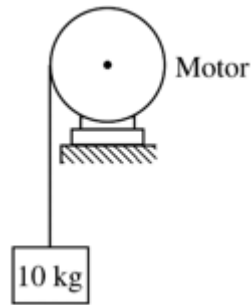

A 10 kg block is attached to a light cord that is wrapped around the pulley of an electric motor, as shown above. At what rate is the motor doing work when it is pulling the block upward with an instantaneous speed of 3 m/s and an upward acceleration of  $2 \text{ m/s}^2$  ?

- (A) 120 W
- (B) 240 W
- (C) 300 W
- (D) 360 W
- (E) 600 W

2. A ball is thrown straight up in the air. When the ball reaches its highest point, which of the following is true?



## AP Physics-1 summer assignment

---

- (A) It is in equilibrium.
  - (B) It has zero acceleration.
  - (C) It has maximum momentum.
  - (D) It has maximum kinetic energy.
  - (E) None of the above
- 

3. A ball is thrown with an initial speed of 20 m/s at an angle of  $60^\circ$  to the ground. If air resistance is negligible, what is the ball's speed at the instant it reaches its maximum height from the ground?

- (A) Zero
  - (B) 10 m/s
  - (C) 14 m/s
  - (D) 17 m/s
  - (E) 20 m/s
- 

4. A car goes from rest to 30 m/s in 12 s with constant acceleration. How long does it take the car to go from rest to 15 m/s with the same acceleration?



**AP Physics-1 summer assignment**

---

- (A) 3.0s
  - (B)  $12/\sqrt{2}s$
  - (C) 6.0s
  - (D)  $12\sqrt{2}s$
  - (E) 24s
- 

5.

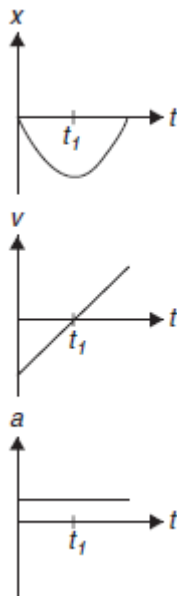

The graphs above represent the position  $x$ , velocity  $v$ , and acceleration  $a$  as a function of time  $t$  for a marble moving in one dimension. Which of the following could describe the motion of the marble?



## AP Physics-1 summer assignment

---

- (A) Rolling along the floor and then bouncing off a wall
  - (B) Rolling down one side of a bowl and then rolling up the other side
  - (C) Rolling up a ramp and then rolling back down
  - (D) Falling and then bouncing elastically off a hard floor
- 

6. A student throws a rock horizontally from the edge of a cliff that is 20 m high. The rock has an initial speed of 10 m/s. If air resistance is negligible, the distance from the base of the cliff to where the rock hits the level ground below the cliff is most nearly

- (A) 5 m
  - (B) 10 m
  - (C) 20 m
  - (D) 40 m
  - (E) 200 m
- 



## AP Physics-1 summer assignment

7.

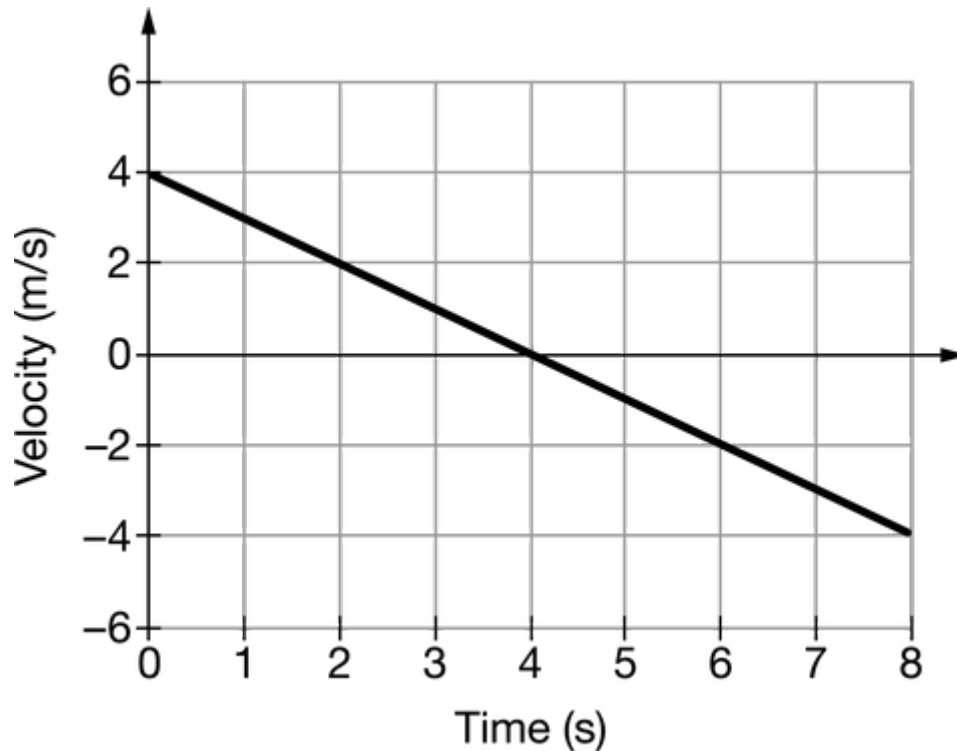

An object is sliding to the right along a straight line on a horizontal surface. The graph shows the object's velocity as a function of time. What is the object's displacement during the time depicted in the graph?

- (A) 0 m
- (B) 1 m
- (C) 8 m
- (D) 16 m

8. A 50.0 N box is at rest on a horizontal surface. The coefficient of static friction between the box and the surface is 0.50, and the coefficient of kinetic friction is 0.30. A horizontal 20.0 N force is then exerted on the box. The magnitude of the acceleration of the box is most nearly



AP Physics-1 summer assignment

---

- (A)  $0 \text{ m/s}^2$
- (B)  $0.5 \text{ m/s}^2$
- (C)  $1.0 \text{ m/s}^2$
- (D)  $4.0 \text{ m/s}^2$
- 

9.

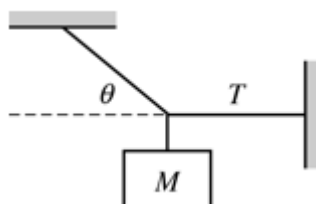

The horizontal wire shown on the right in the figure above will break when the tension in it exceeds the value  $T_{\max}$ . What is the maximum mass  $M$  that the hanging object can have without the horizontal wire breaking? (Assume the wire on the left does not break prior to the horizontal wire breaking.)

- (A)  $\frac{T_{\max}}{g}$
- (B)  $\frac{T_{\max}}{g \sin \theta}$
- (C)  $\frac{T_{\max}}{g \cos \theta}$
- (D)  $\frac{T_{\max}}{g \tan \theta}$
- (E)  $\frac{T_{\max} \tan \theta}{g}$
- 



**AP Physics-1 summer assignment**

---

10. A box is given a sudden push up a ramp. Friction between the box and the ramp is not negligible. Which of the following diagrams best represents the directions of the actual forces acting on the box as it moves upward after the push?

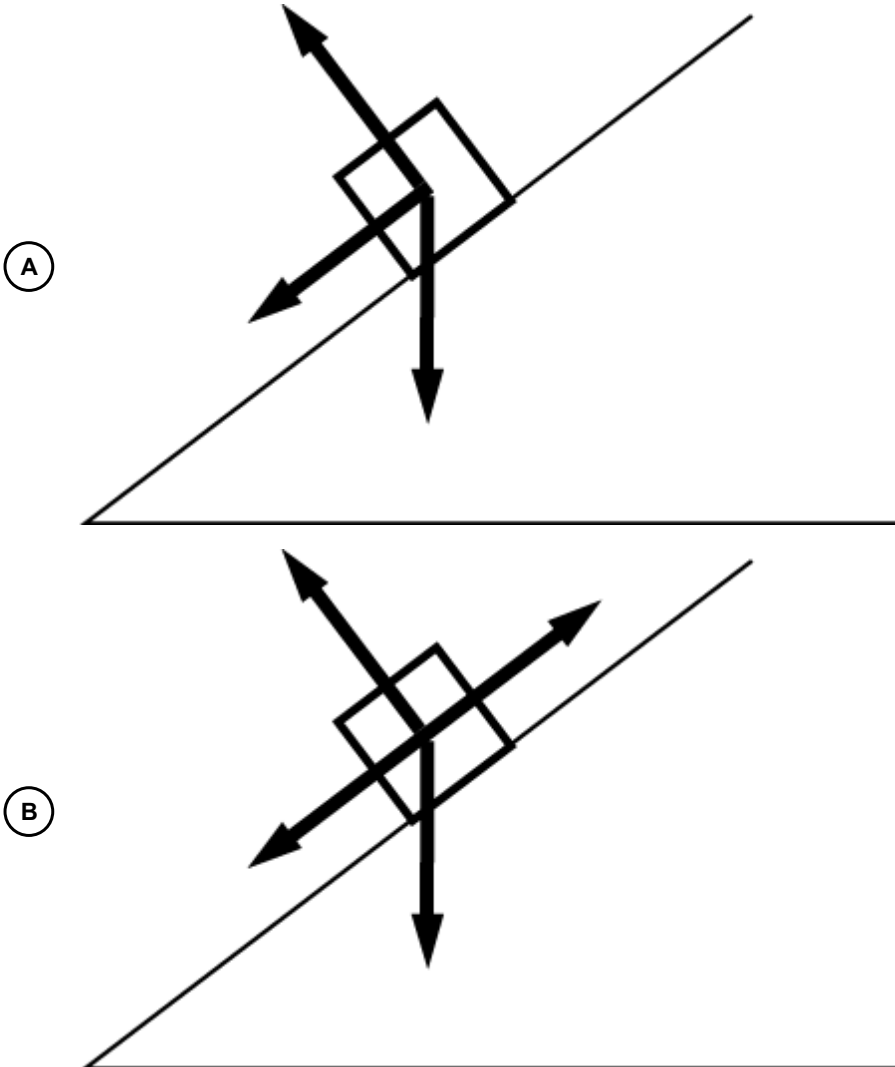

### AP Physics-1 summer assignment

---

(C)

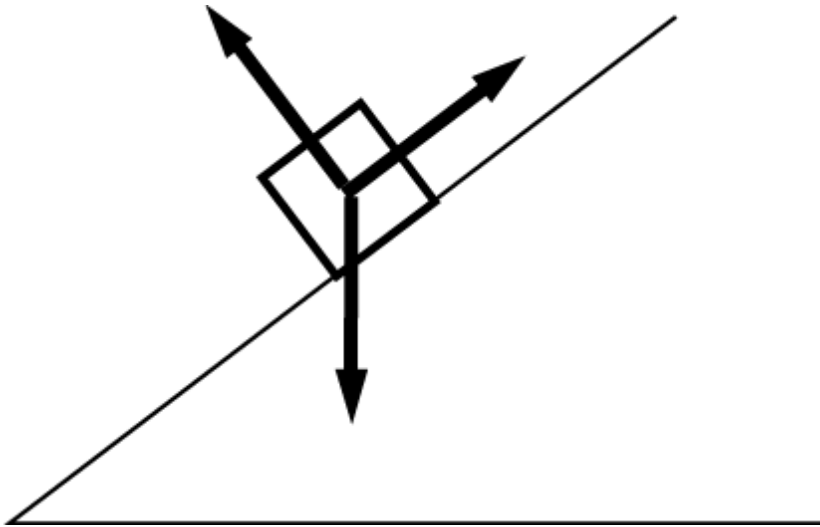

(D)

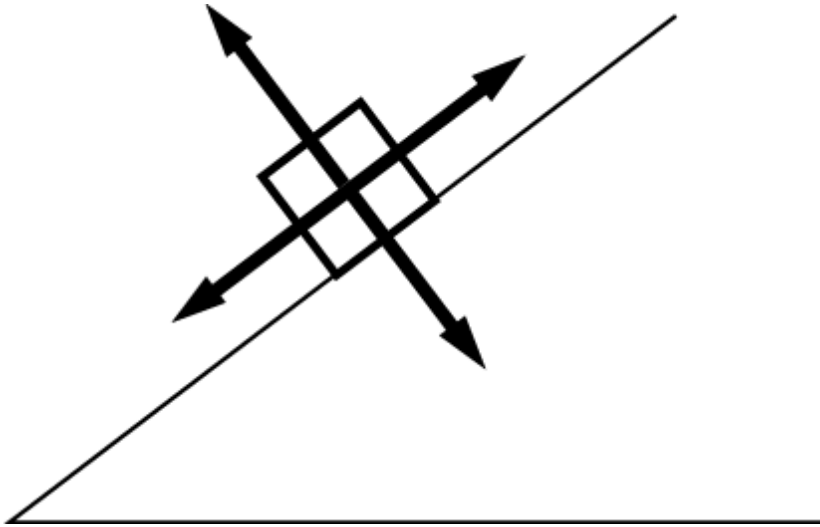

(E)

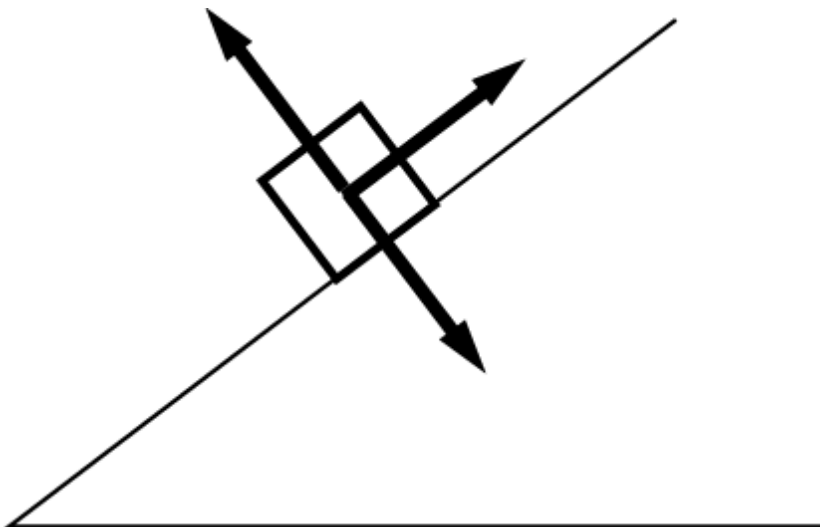



**AP Physics-1 summer assignment**

---

11.



A rock attached to a string swings in a vertical circle, as shown above, with negligible air resistance. Which of the following diagrams could correctly show all the forces on the rock when the string is in the position above?

- (A)
- (B)
- (C)
- (D)
- (E)

---

12. A spaceship is traveling from Earth to the Moon. Which of the following is true of the gravitational force on the ship due to the two objects when the ship is equidistant from Earth and the Moon?



**AP Physics-1 summer assignment**

---

- (A) There is no net force because the ship is beyond the influence of Earth and the Moon.
- (B) There is no net force because the forces exerted by Earth and the Moon balance.
- (C) There is a net force because the force exerted by Earth is smaller than that exerted by the Moon.
- (D) There is a net force because the force exerted by Earth is greater than that exerted by the Moon.
- (E) There is a net force because the ship must be accelerating toward the Moon.
- 

**13.** An object is moving to the west at a constant speed. Three forces are exerted on the object. One force is 10 N directed due north, and another is 10 N directed due west. What is the magnitude and direction of the third force if the object is to continue moving to the west at a constant speed?

- (A)  $10\sqrt{3}$  N , directed northwest
- (B)  $10\sqrt{3}$  N , directed southeast
- (C)  $10\sqrt{2}$  N , directed northwest
- (D)  $10\sqrt{2}$  N , directed southeast
- 



## AP Physics-1 summer assignment

14.

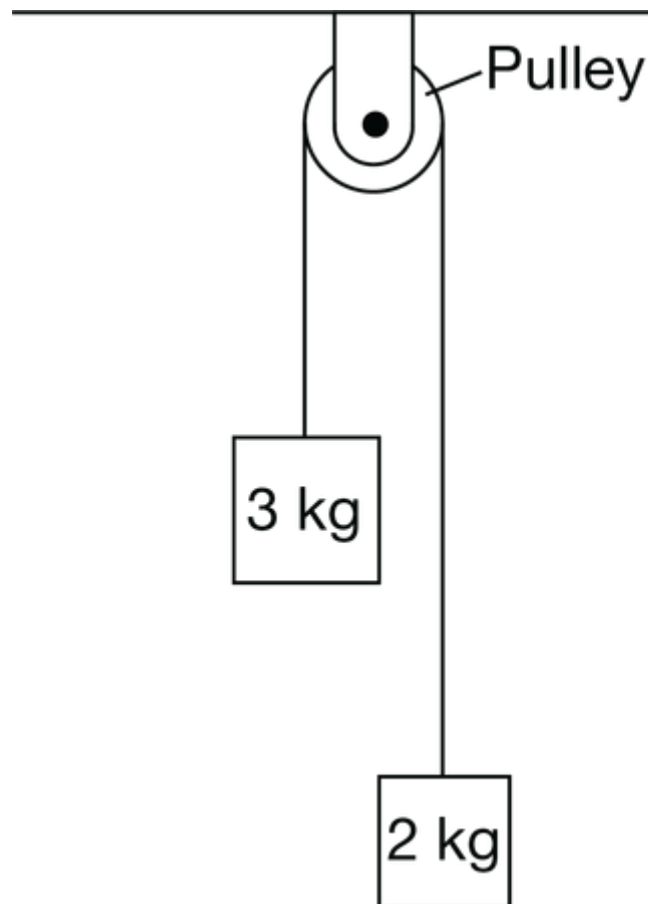

An Atwood's machine is set up by suspending two blocks connected by a string of negligible mass over a pulley, as shown above. The blocks are initially held at rest and then released at time  $t_0 = 0\text{ s}$ . The speed of the  $3\text{ kg}$  block at time  $t_1 = 2.0\text{ s}$  is most nearly

- (A)  $2.0\text{ m/s}$
- (B)  $4.0\text{ m/s}$
- (C)  $7.0\text{ m/s}$
- (D)  $10.0\text{ m/s}$

15. A tennis ball is thrown against a vertical concrete wall that is fixed to the ground. The ball bounces off the wall. How does the force exerted by the ball on the wall compare with the force exerted by the wall on the ball?



**AP Physics-1 summer assignment**

---

- (A) The force exerted by the ball is greater.
- (B) The forces exerted by the ball and the wall have the same magnitude.
- (C) The force exerted by the ball is smaller.
- (D) The relative magnitudes of the forces cannot be determined without knowing how long the ball and the wall are in contact.
- 

16.

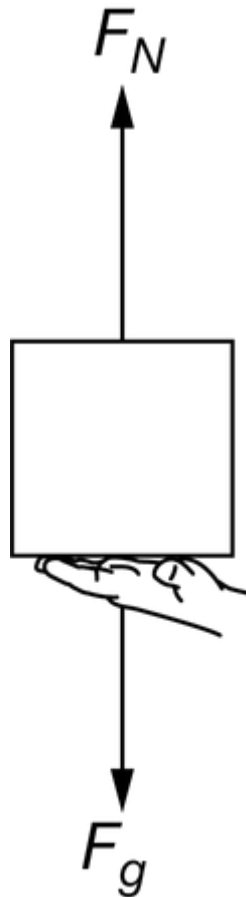

The diagram above represents the forces exerted on a box that a child is holding.  $F_N$  represents the force applied by the child's hand, and  $F_g$  represents the weight of the box. The child begins to raise the box with increasing speed. Which of the following claims is correct about force  $F_h$  that is exerted by the box on the child's hand as the box is being raised?



**AP Physics-1 summer assignment**

---

- (A)  $F_h = F_N$ , where  $F_N$  does not change as the child raises the box.
- (B)  $F_h = F_N$ , where  $F_N$  is larger as the box is being raised than when it was being held.
- (C)  $F_h = F_g$ , where  $F_g$  does not change as the child raises the box.
- (D)  $F_h = F_g$ , where  $F_g$  is larger as the box is being raised than when it was being held.
- 

17. A toy doll and a toy robot are standing on a frictionless surface facing each other. The doll has a mass of **0.20 kg**, and the robot has a mass of **0.30 kg**. The robot pushes on the doll with a force of **0.30 N**. The magnitude of the acceleration of the robot is

- (A) zero
- (B)  $0.60 \text{ m/s}^2$
- (C)  $1.0 \text{ m/s}^2$
- (D)  $1.5 \text{ m/s}^2$
- 



**AP Physics-1 summer assignment**

---

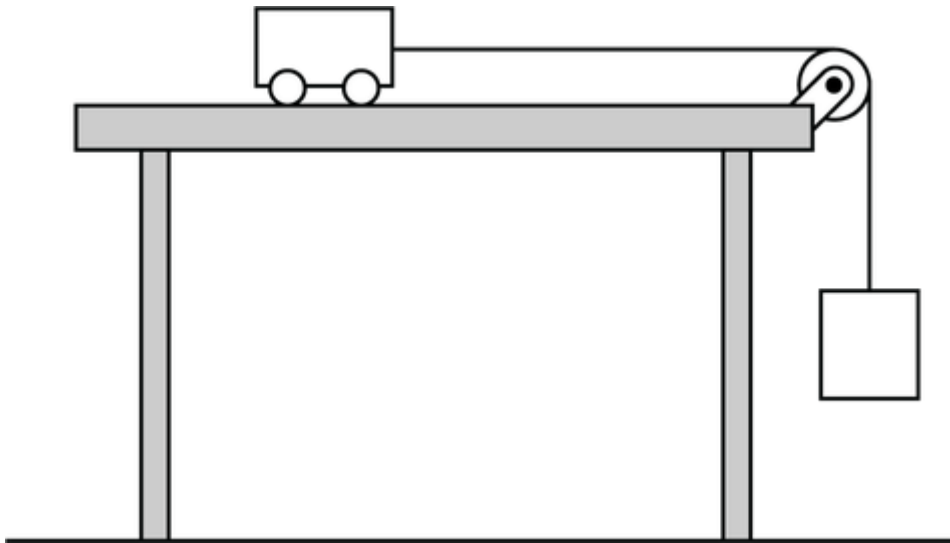

Students work together during an experiment about Newton's laws. The students use a setup that consists of a cart of known mass connected to one end of a string that is looped over a pulley of negligible friction, with its other end connected to a hanging mass. The cart is initially at rest on a horizontal surface and rolls without slipping when released. The inertia of the cart's wheels is negligible. Students have access to common laboratory equipment to make measurements of components of the system.

18. The students double the mass that hangs from the string. They also replace the original cart with a new cart that has double the mass. By doubling both masses, how will the tension in the string and the acceleration of the cart change?
- (A) The tension and the acceleration will double.
  - (B) The tension will double, but the acceleration will stay the same.
  - (C) The tension will stay the same, but the acceleration will double.
  - (D) The tension and the acceleration will stay the same.
- 



AP Physics-1 summer assignment

---

19.

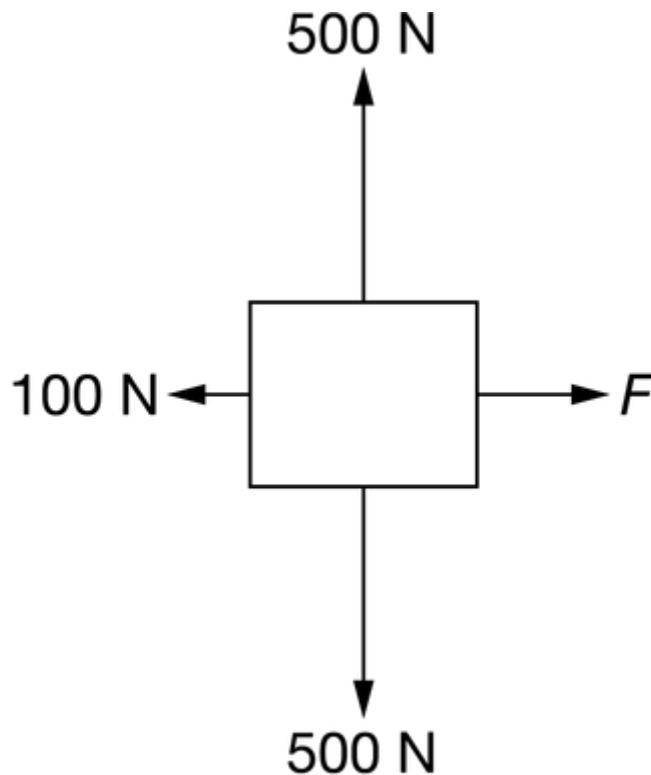

Note: Figure not drawn to scale.

The figure above shows the forces exerted on a block that is sliding on a rough horizontal surface: The weight of the block is  $500\text{ N}$ , the normal force is  $500\text{ N}$ , the frictional force is  $100\text{ N}$ , and there is an unknown force  $F$  exerted to the right. The acceleration of the block is  $0.4\text{ m/s}^2$ . The value of  $F$  is most nearly

- (A) 20 N
  - (B) 80 N
  - (C) 110 N
  - (D) 120 N
- 



**AP Physics-1 summer assignment**

---

20. A car with speed  $v$  and an identical car with speed  $2v$  both travel the same circular section of an unbanked road. If the frictional force required to keep the faster car on the road without skidding is  $F$ , then the frictional force required to keep the slower car on the road without skidding is

(A)  $4F$

(B)  $2F$

(C)  $F$

(D)  $F/2$

(E)  $F/4$

---

21. A new planet is discovered that has twice the Earth's mass and twice the Earth's radius. On the surface of this new planet, a person who weighs 500 N on Earth would experience a gravitational force of

(A) 125 N

(B) 250 N

(C) 500 N

(D) 1000 N

(E) 2000 N

---

22. A planet with half Earth's mass and half Earth's radius is discovered. What would an astronaut who weighs 800 N on Earth weigh on the planet?





**AP Physics-1 summer assignment**

---

- (A) 100 N
  - (B) 200 N
  - (C) 400 N
  - (D) 800 N
  - (E) 1600 N
- 

23. A satellite of mass  $m$  and speed  $v$  moves in a stable, circular orbit around a planet of mass  $M$ . What is the radius of the satellite's orbit?

- (A)  $GM/mv$
  - (B)  $Gv/mM$
  - (C)  $GM/v^2$
  - (D)  $GmM/v$
  - (E)  $GmM/v^2$
- 

24. An object attached to one end of a string moves in a circle at constant speed. Which of the following is correct?



**AP Physics-1 summer assignment**

---

- (A) The object is accelerating as it moves.
- (B) The object's velocity is the same as its speed.
- (C) The object does not require a force to keep its state of circular motion.
- (D) If the string breaks, the object will keep its circular motion.
- (E) If the string breaks, the object will move radially away from the center of the circle.
- 

25. A 10 kg object is near a planet's surface such that the gravitational field strength is  $4 \frac{\text{N}}{\text{kg}}$ . With what force is the planet attracted to the 10 kg object?

- (A)  $4 \frac{\text{N}}{\text{kg}}$
- (B) 10 N
- (C) 40 N
- (D) 100 N
- 

26. A ball is dropped from rest and falls to the floor. The initial gravitational potential energy of the ball-Earth-floor system is 10 J. The ball then bounces back up to a height where the gravitational potential energy is 7 J. What was the mechanical energy of the ball-Earth-floor system the instant the ball left the floor?



**AP Physics-1 summer assignment**

---

- (A) 0 J
- (B) 3 J
- (C) 7 J
- (D) 10 J
- 

27. A ball of mass  $m$  and momentum  $p$  has kinetic energy equal to which of the following?

- (A)  $\frac{1}{2} \frac{p^2}{m}$
- (B)  $\frac{p^2}{m}$
- (C)  $2 \frac{p^2}{m}$
- (D)  $\frac{1}{2} \frac{m}{p^2}$
- (E)  $2 \frac{m}{p^2}$
- 

28.

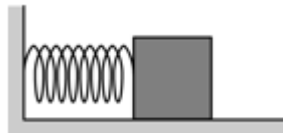

A block on a horizontal surface of negligible friction is placed in contact with an ideal spring, as shown above. The block is moved to the left so that the spring is compressed a distance  $x$  from equilibrium and then released from rest. The block has kinetic energy  $K_1$  when it separates from the spring. When the spring is compressed a distance  $2x$  and the block is released from rest, the kinetic energy of the block when it separates from the spring is



**AP Physics-1 summer assignment**

---

(A)  $K_1/2$

(B)  $K_1$

(C)  $\sqrt{2}K_1$

(D)  $2K_1$

(E)  $4K_1$

---

29. A rocket is continuously firing its engines as it accelerates away from Earth. For the first kilometer of its ascent, the mass of fuel ejected is small compared to the mass of the rocket. For this distance, which of the following indicates the changes, if any, in the kinetic energy of the rocket, the gravitational potential energy of the Earth-rocket system, and the mechanical energy of the Earth-rocket system?

(A) **Rocket Kinetic Energy System Gravitational Potential Energy System Mechanical Energy**  
Increasing    Increasing    Increasing

(B) **Rocket Kinetic Energy System Gravitational Potential Energy System Mechanical Energy**  
Increasing    Increasing    Constant

(C) **Rocket Kinetic Energy System Gravitational Potential Energy System Mechanical Energy**  
Increasing    Decreasing    Decreasing

(D) **Rocket Kinetic Energy System Gravitational Potential Energy System Mechanical Energy**  
Decreasing    Increasing    Constant

---



**AP Physics-1 summer assignment**

---

30. A rubber ball with mass 0.20 kg is dropped vertically from a height of 1.5 m above a floor. The ball bounces off of the floor, and during the bounce 0.60 J of energy is dissipated. What is the maximum height of the ball after the bounce?

- (A) 0.30 m
- (B) 0.90 m
- (C) 1.2 m
- (D) 1.5 m
- 

31.

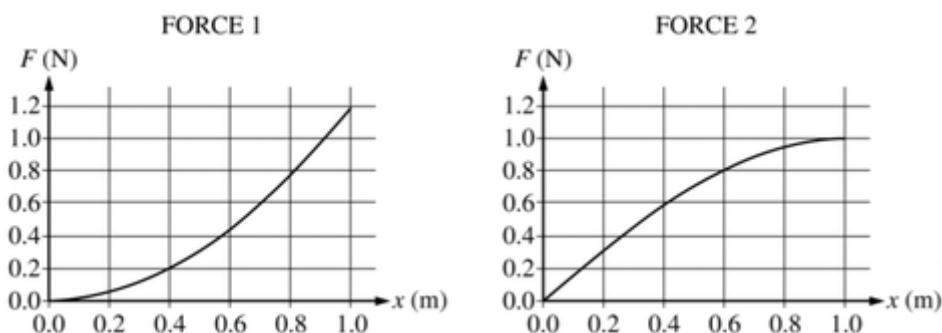

The graphs above show the magnitude  $F$  of a force exerted on an object as a function of the object's position  $x$  for two trials in an experiment.  $W_1$  and  $W_2$  are the work done on the object by force 1 and force 2, respectively. How do  $W_1$  and  $W_2$  compare, and why?

- (A)  $W_1 > W_2$ , because the maximum value of force 1 is greater than the maximum value of force 2.
- (B)  $W_1 > W_2$ , because the slope of force 1's graph increases, while the slope of force 2's graph decreases.
- (C)  $W_1 < W_2$ , because the average value of force 1 is smaller than the average value of force 2.
- (D)  $W_1 < W_2$ , because at the midpoint,  $x = 0.5$  m, the value of force 1 is less than the value of force 2.
- 



**AP Physics-1 summer assignment**

---

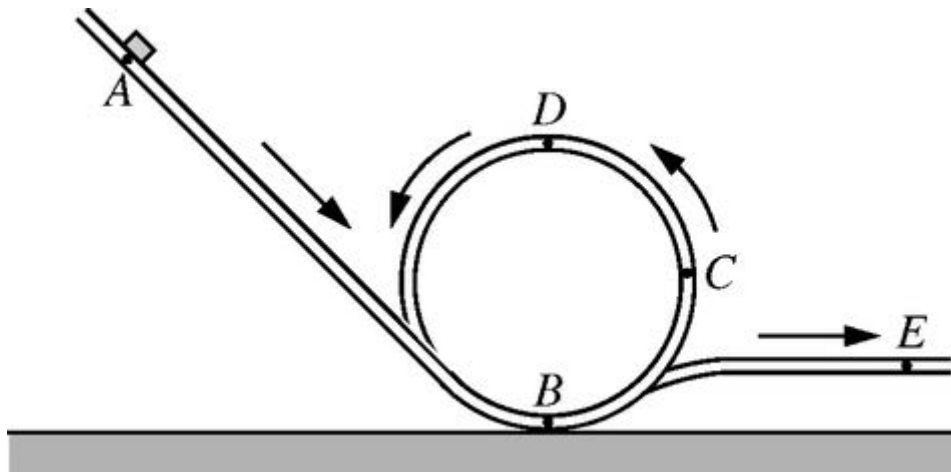

A block released from rest at position A slides with negligible friction down an inclined track, around a vertical loop, and then along a horizontal portion of the track, as shown above. The block never leaves the track.

32. After the block is released, in which of the following sequences of positions is the speed of the block ordered from fastest to slowest?

- (A)  $B C D E$
- (B)  $B E C D$
- (C)  $D C E B$
- (D)  $E B C D$
- (E)  $E D C B$

33. An automobile traveling on a straight, level road has an initial speed  $v$  when the brakes are applied. In coming to rest with a constant acceleration, it travels a distance  $x$ . How far would the automobile travel in coming to rest if it had the same acceleration but an initial speed  $2v$ ?



**AP Physics-1 summer assignment**

---

(A)  $\frac{1}{4}x$

(B)  $\frac{1}{2}x$

(C)  $x$

(D)  $2x$

(E)  $4x$

---



## AP Physics-1 summer assignment

34.

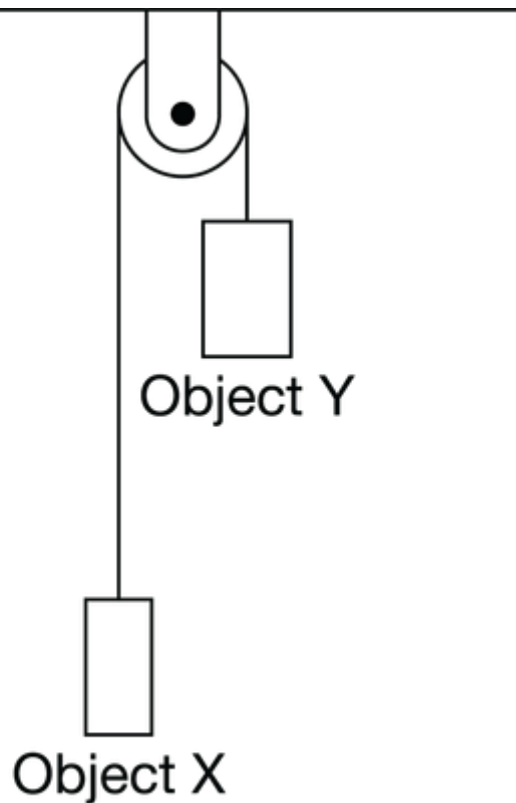

Objects **X** and **Y** are connected by a string of negligible mass and suspended vertically over a pulley of negligible mass, creating an Atwood's machine, as shown in the figure. The objects are initially at rest, and the mass of Object **Y** is greater than the mass of Object **X**. As Object **Y** falls, how does the gravitational potential energy of the Object **X**-Object **Y**-Earth system change? All frictional forces are considered to be negligible.

- (A) The gravitational potential energy increases because the center of mass of Object **X** and Object **Y** moves upward.
- (B) The gravitational potential energy increases because the center of mass of Object **X** and Object **Y** moves downward.
- (C) The gravitational potential energy decreases because the center of mass of Object **X** and Object **Y** moves upward.
- (D) The gravitational potential energy decreases because the center of mass of Object **X** and Object **Y** moves downward.





## AP Physics-1 summer assignment

35.

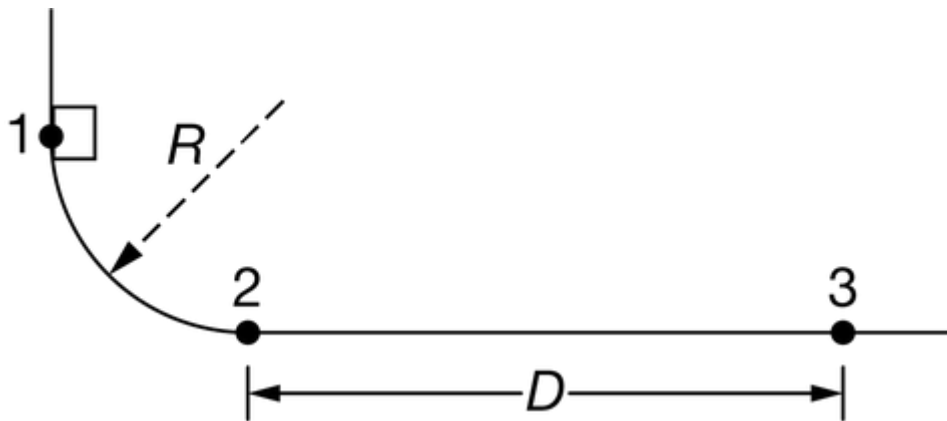

A block of mass  $M$  is released from rest at point 1, as shown in the figure. The block slides without frictional forces along the circular arc but encounters frictional forces as soon as it reaches the horizontal portion of the track at point 2. The block travels a distance  $D$  along the horizontal track before coming to rest at point 3. Consider the block-Earth system. In terms of the mechanical energy of the system, which of the following claims is correct, and why?

- (A) The system is open, because there is a net force exerted on the block.
- (B) The system is open, because the block's velocity is zero at points 1 and 3.
- (C) The system is closed, because there is a net force exerted on the block.
- (D) The system is closed, because the block's velocity is zero at points 1 and 3.



AP Physics-1 summer assignment

---

36.

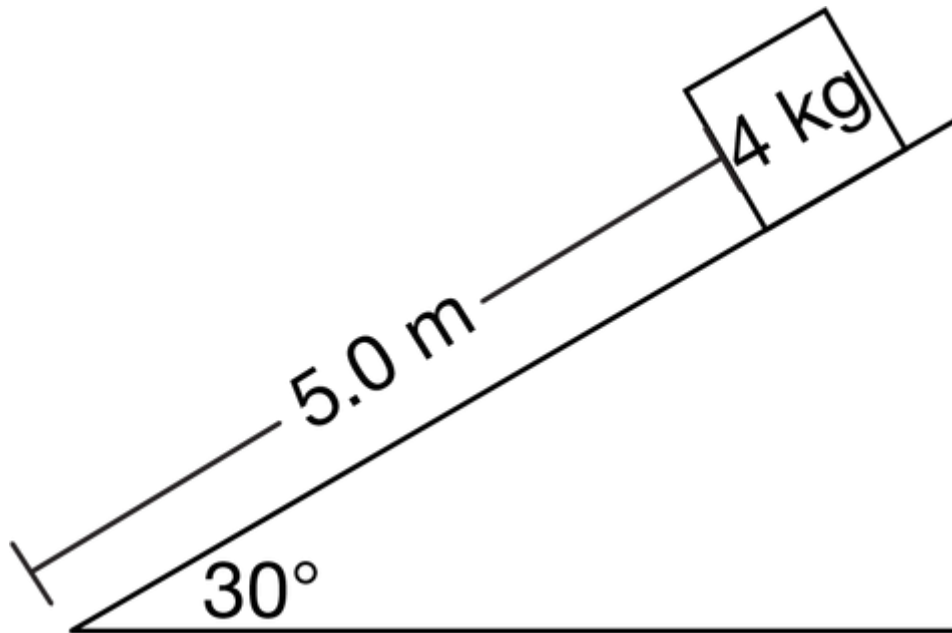

A  $4\text{ kg}$  block is pushed up an incline that makes a  $30^\circ$  angle with the horizontal, as shown in the figure. Once the block is pushed a distance of  $d = 5.0\text{ m}$  up the incline, the block remains at rest. What is the approximate change in the gravitational potential energy of the block-Earth system when the block is held at rest compared to its original location at the bottom of the incline?

- (A)  $0\text{ J}$
- (B)  $100\text{ J}$
- (C)  $100\sqrt{3}\text{ J}$
- (D)  $200\text{ J}$
- 



## AP Physics-1 summer assignment

37.

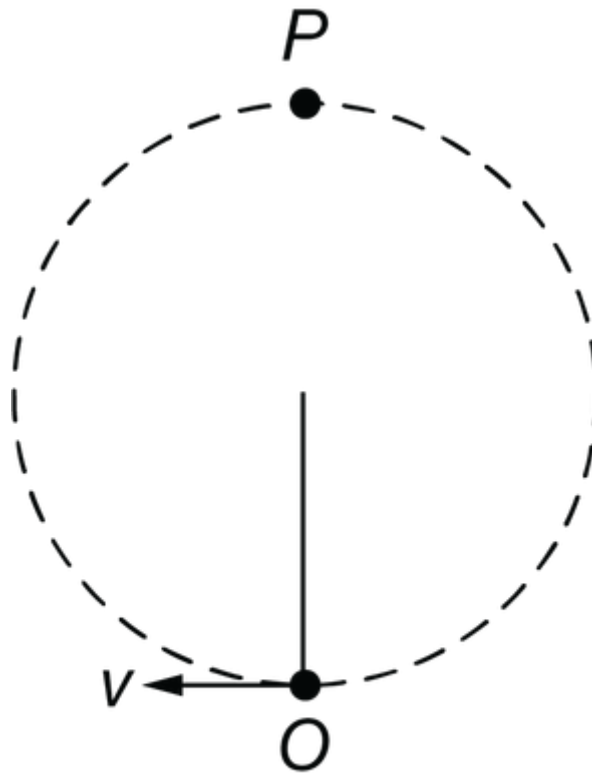

## Side View

An object of mass  $M$  is attached to a string of negligible mass and spun in a vertical circle of radius  $R$ , as shown in the figure above. As the object's height increases, its speed decreases such that the object-Earth system's total mechanical energy remains constant. By how much does the object's kinetic energy decrease in moving from point  $O$ , the lowest point on the circle, to point  $P$ , the highest point on the circle?

- (A)  $\frac{1}{2}MgR$
- (B)  $MgR$
- (C)  $\sqrt{2}MgR$
- (D)  $2MgR$

Refer to the following material for answering the questions.



## AP Physics-1 summer assignment

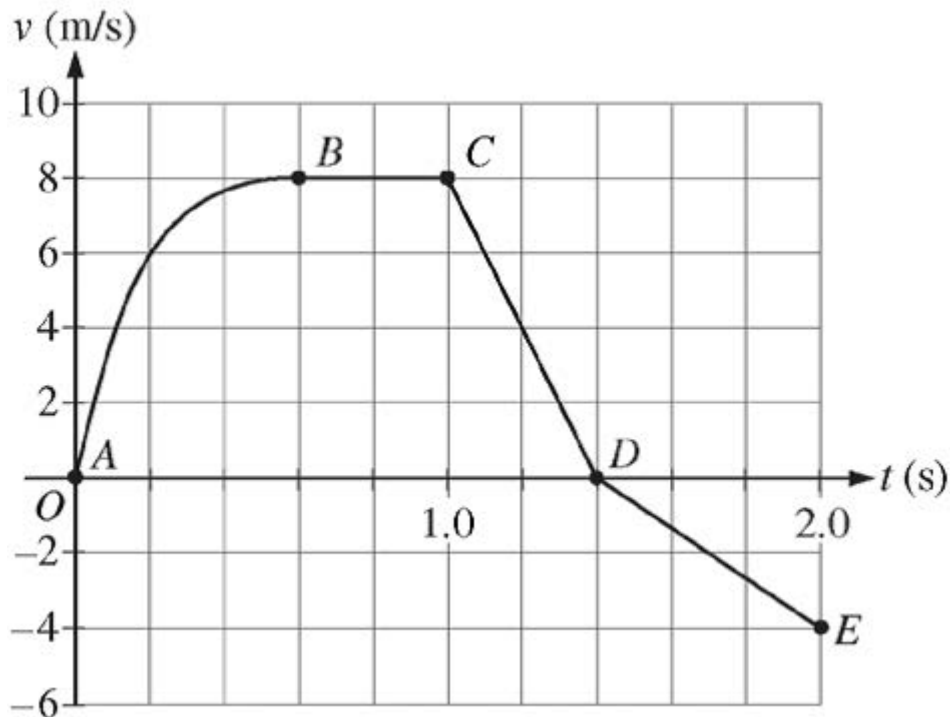

A cart is constrained to move along a straight line. A varying net force along the direction of motion is exerted on the cart. The cart's velocity  $v$  as a function of time  $t$  is shown in the graph above. The five labeled points divide the graph into four sections.

38. During some part of the motion, the work done on the cart is negative. What feature of the motion indicates this?
- (A) The speed is increasing.
  - (B) The speed is decreasing.
  - (C) The acceleration is positive.
  - (D) The acceleration is negative.



## AP Physics-1 summer assignment

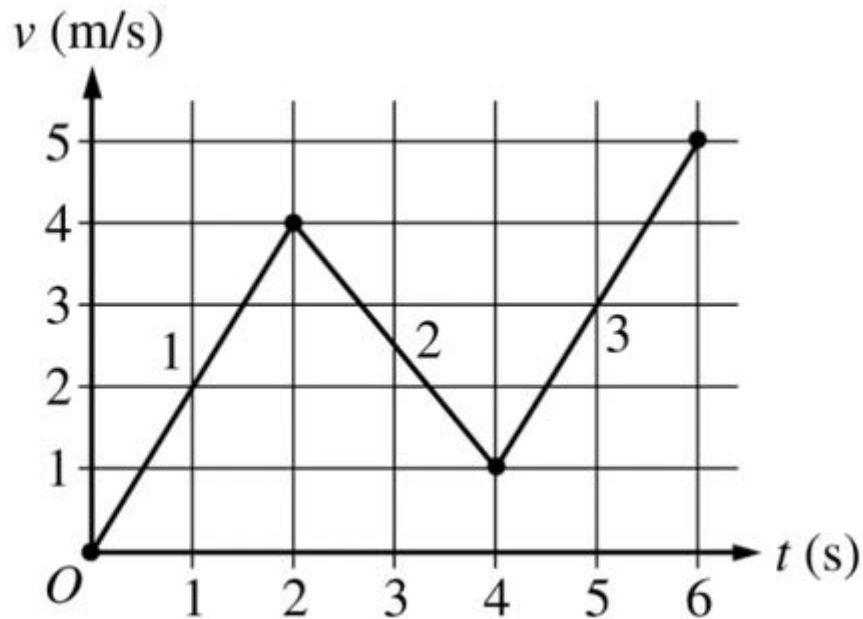

The graph above shows velocity  $v$  as a function of time  $t$  for a 0.50 kg object traveling along a straight line. The graph has three segments labeled 1, 2, and 3. A rope exerts a constant force of magnitude  $F_T$  on the object along its direction of motion the whole time. During segment 2 only, a frictional force of magnitude  $F_f$  is also exerted on the object.

39. For another identical object initially at rest, no frictional force is exerted during segment 2 (between  $t = 2$  s and  $t = 4$  s). A rope exerts the same constant force of magnitude  $F_T$  as in the previous scenario. What is the change in the object's kinetic energy during segment 2?

- (A) 3.75 J
- (B) 4.00 J
- (C) 12.0 J
- (D) 16.0 J



**AP Physics-1 summer assignment**

---

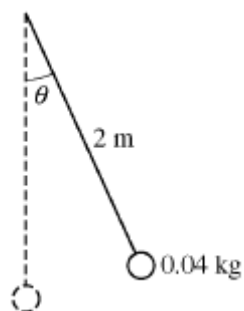

The pendulum illustrated above has a length of 2 m and a bob of mass 0.04 kg. It is held at an angle  $\theta$ , as shown, where  $\cos\theta = 0.9$ .

---

**40.** If the pendulum is released from rest, the maximum speed the bob attains is most nearly

- (A) 1 m/s
  - (B)  $\sqrt{2}m/s$
  - (C) 2m/s
  - (D) 4m/s
  - (E) 6m/s
- 

**41.** The frequency of oscillation is most nearly



**AP Physics-1 summer assignment**

---

- (A)  $4\pi$  Hz
- (B)  $2\pi\sqrt{0.2}$  Hz
- (C)  $(0.25 / \pi)$  Hz
- (D)  $(\sqrt{0.2} / (2\pi))$  Hz
- (E)  $(\sqrt{5} / (2\pi))$  Hz
- 

42. In which of the following situations is the kinetic energy of the object decreasing?

- (A) A sphere is dropped from a building.
- (B) A satellite is moving in a circular orbit around Earth.
- (C) A baseball is heading upward after being thrown at an angle.
- (D) An elevator is moving upward at a constant velocity.
- 



## AP Physics-1 summer assignment

43.

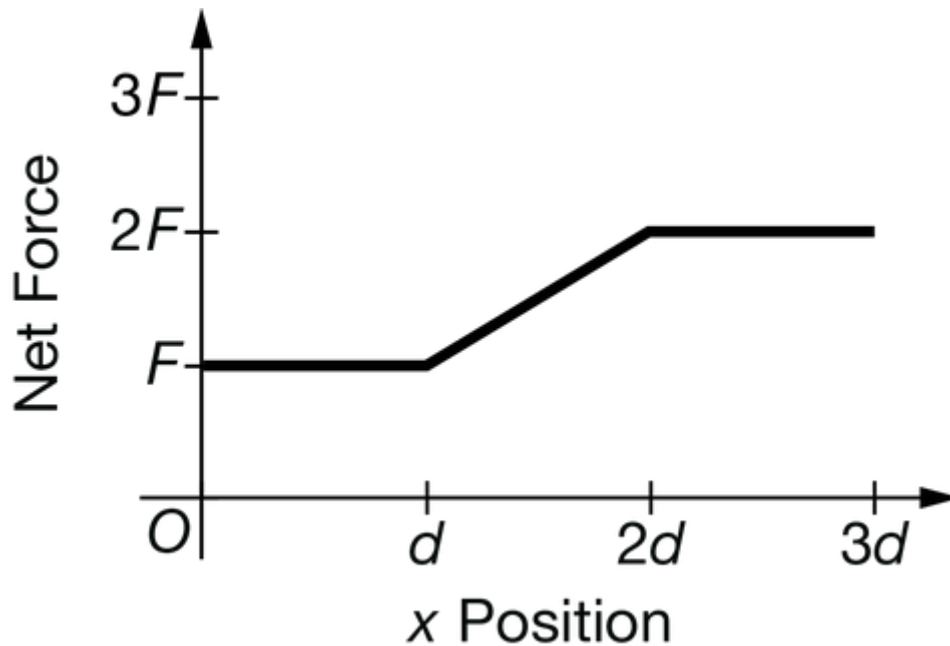

A graph of the net force  $F$  exerted on an object as a function of  $x$  position is shown for the object of mass  $M$  as it travels a horizontal distance  $3d$ . Which expression represents the change in the kinetic energy of the object?

- (A)  $3Fd$
- (B)  $3.5Fd$
- (C)  $4.5Fd$
- (D)  $6Fd$

44. A  $4 \text{ kg}$  object moving to the left collides with and sticks to a  $3 \text{ kg}$  object moving to the right. Which of the following is true of the motion of the combined objects immediately after the collision?





**AP Physics-1 summer assignment**

---

- (A) They must be moving to the left.
- (B) They must be moving to the right.
- (C) They must be at rest.
- (D) The motion cannot be determined without knowing the speeds of the objects before the collision.
- 

45. A 1.0 kg lump of clay is sliding to the right on a frictionless surface with speed 2 m/s . It collides head-on and sticks to a 0.5 kg metal sphere that is sliding to the left with speed 4 m/s . What is the kinetic energy of the combined objects after the collision?

- (A) 6J
- (B) 4J
- (C) 2J
- (D) 0J
- 

46. A 12 kg box sliding on a horizontal floor has an initial speed of 4.0 m/s. The coefficient of friction between the box and the floor is 0.20. The box moves a distance of 4.0 m in 2.0 s. The magnitude of the change in momentum of the box during this time is most nearly



**AP Physics-1 summer assignment**

---

- (A) 12 kg·m/s
  - (B) 48 kg·m/s
  - (C) 60 kg·m/s
  - (D) 96 kg·m/s
- 

47. A dog of mass 10 kg sits on a skateboard of mass 2 kg that is initially traveling south at 2 m/s. The dog jumps off with a velocity of 1 m/s north relative to the ground. Which of the following is the best estimate of the velocity of the skateboard immediately after the dog has jumped?

- (A) 1 m/s north
  - (B) 1 m/s south
  - (C) 3 m/s south
  - (D) 7 m/s south
  - (E) 17 m/s south
- 

48. A force of constant magnitude  $F$  and fixed direction acts on an object of mass  $m$  that is initially at rest. If the force acts for a time interval  $\Delta t$  over a displacement  $\Delta x$ , what is the magnitude of the resultant change in the linear momentum of the object?



**AP Physics-1 summer assignment**

---

- (A)  $F \Delta t$
- (B)  $F \Delta x$
- (C)  $F\Delta t / m$
- (D)  $F\Delta x / m$
- (E)  $mF \Delta t$
- 

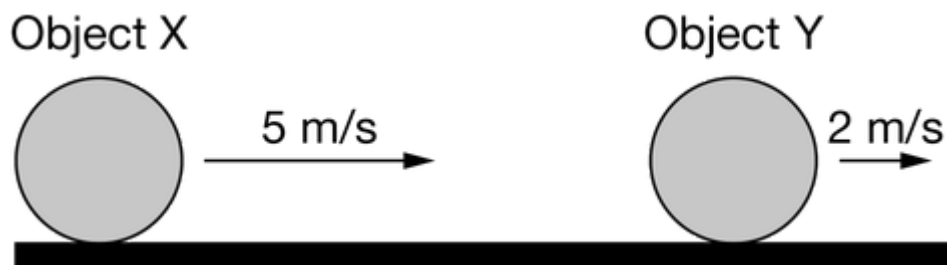

Two objects of the same mass travel in the same direction along a horizontal surface. Object X has a speed of  $5 \frac{m}{s}$  and object Y has a speed of  $2 \frac{m}{s}$ , as shown in the figure. After a period of time, object X collides with object Y.

49. Consider the situation in which the objects collide but do not stick together. Which of the following predictions is true about the center of mass of the two-object system immediately after the collision?



**AP Physics-1 summer assignment**

---

- (A) The center of mass does not move.
- (B) The velocity of the center of mass does not change.
- (C) The velocity of the center of mass decreases in speed.
- (D) The velocity of the center of mass increases in speed.
- 

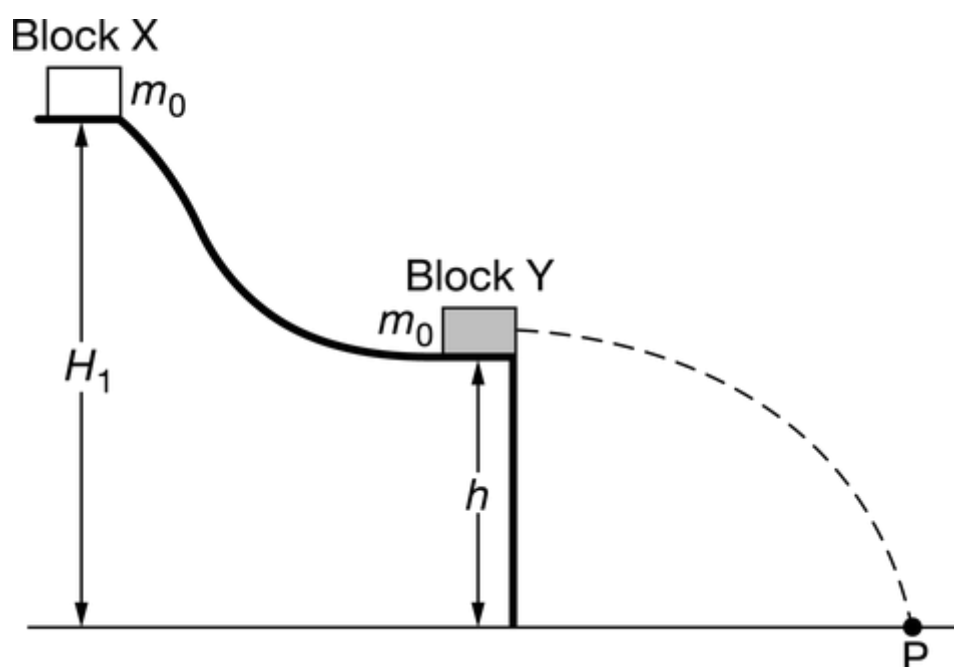

Block X of mass  $m_0$  is at rest at the top of a ramp, and the block's center of mass is at a height  $H_1$  above the ground. Block X is then released from rest, and it slides down the ramp and collides with block Y of mass  $m_0$ , which is initially at rest and has its center of mass at a height  $h$  above the ground. At the moment before the collision, block X has a speed of  $v_0$ . After the collision, block Y travels such that it lands at point P.

50. Consider the block X-block Y system from the moment in time that block X is released from rest to the moment immediately after block X collides with block Y. Which of the following claims best describes the system?



**AP Physics-1 summer assignment**

---

- (A) Because the total momentum of the system does not remain constant, the system is open.
- (B) Because the total kinetic energy of the system does not remain constant, the system is open.
- (C) Because the total momentum of the system remains constant, the system is closed.
- (D) Because the total kinetic energy of the system remains constant, the system is closed.
- 

51.

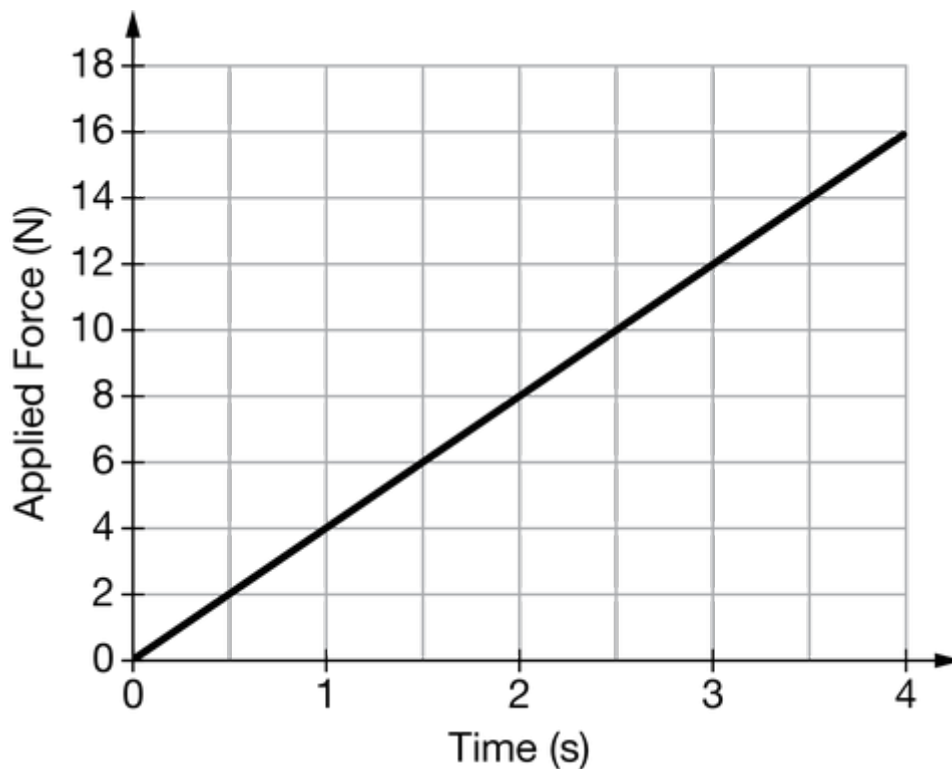

A **2 kg** object travels across a horizontal surface with a constant speed of  $6 \frac{\text{m}}{\text{s}}$ . An applied force that increases with time is then exerted on the object. A graph of the force exerted on the object as a function of time is shown. The applied force is in the direction of the object's displacement. All frictional forces are considered to be negligible. What is the object's speed after the force has been applied for **4 s**?



**AP Physics-1 summer assignment**

---

(A)  $16 \frac{\text{m}}{\text{s}}$

(B)  $22 \frac{\text{m}}{\text{s}}$

(C)  $32 \frac{\text{m}}{\text{s}}$

(D)  $44 \frac{\text{m}}{\text{s}}$

---

52.

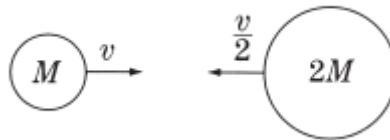

A ball of mass  $M$  and speed  $v$  collides head-on with a ball of mass  $2M$  and speed  $\frac{v}{2}$ , as shown above. If the two balls stick together, their speed after the collision is

(A) 0

(B)  $\frac{v}{2}$

(C)  $\frac{\sqrt{2}v}{2}$

(D)  $\frac{\sqrt{3}v}{2}$

(E)  $\frac{3v}{2}$

---



## AP Physics-1 summer assignment

53.

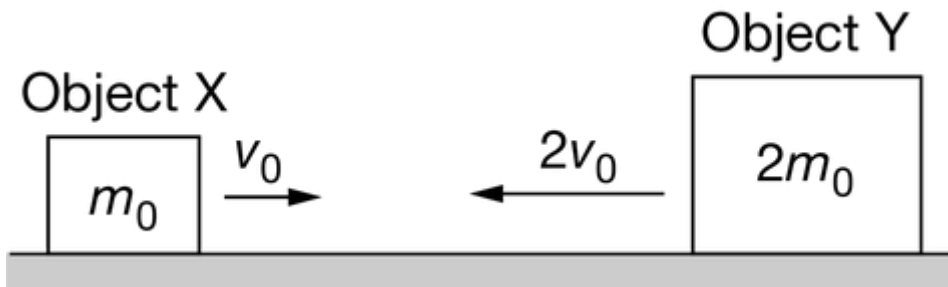

Object X of mass  $m_0$  travels to the right with a velocity  $v_0$ . Object Y of mass  $2m_0$  moves to the left at  $2v_0$ , as shown in the figure. The objects collide and then stick together. What is the change in kinetic energy of the two-object system from immediately before the collision to immediately after the collision?

- (A) The kinetic energy increases by  $6m_0v_0^2$ .
- (B) The kinetic energy increases by  $3m_0v_0^2$ .
- (C) The kinetic energy decreases by  $6m_0v_0^2$ .
- (D) The kinetic energy decreases by  $3m_0v_0^2$ .

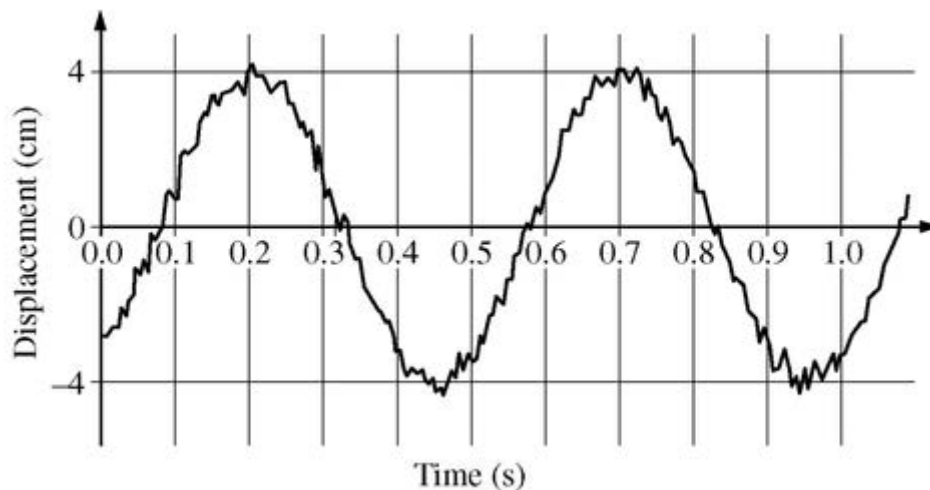

A student sets an object attached to a spring into oscillatory motion and uses a position sensor to record the displacement of the object from equilibrium as a function of time. A portion of the recorded data is



**AP Physics-1 summer assignment**

---

shown in the figure above.

---

54. The speed of the object at time  $t = 0.65$  s is most nearly equal to which of the following?
- (A) The value of the graph at 0.65 s
  - (B) The slope of the line connecting the origin and the point on the graph at 0.65 s
  - (C) The slope of the line connecting the point where the graph crosses the time axis near 0.57 s and the point on the graph at 0.65 s
  - (D) The slope of the tangent to a best-fit sinusoidal curve at 0.65 s
- 

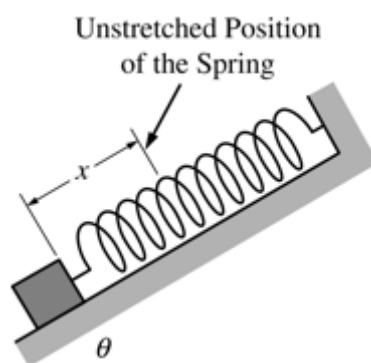

An object of mass  $m$  is attached to a spring on a frictionless inclined plane that makes an angle  $\theta$  with the horizontal, as shown above. The object is released from rest with the spring in its unstretched position. As the object moves on the plane, its displacement from the unstretched position is  $x$ .

---

55. The object subsequently oscillates about an equilibrium position at a displacement  $x_0$  from the unstretched position of the spring. What is the spring constant of the spring?





**AP Physics-1 summer assignment**

---

(A)  $\frac{mg}{x_0 \cos \theta}$

(B)  $\frac{mg}{x_0 \sin \theta}$

(C)  $\frac{mg \tan \theta}{x_0}$

(D)  $\frac{mg \cos \theta}{x_0}$

(E)  $\frac{mg \sin \theta}{x_0}$

---

56.

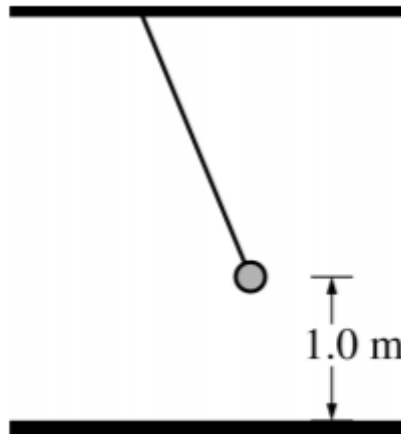

A 0.5 kg pendulum bob is raised to 1.0 m above the floor, as shown in the figure above. The bob is then released from rest. When the bob is 0.8 m above the floor, its speed is most nearly

(A) 5 m/s

(B) 4 m/s

(C) 2 m/s

(D) 1 m/s

---



## AP Physics-1 summer assignment

57.

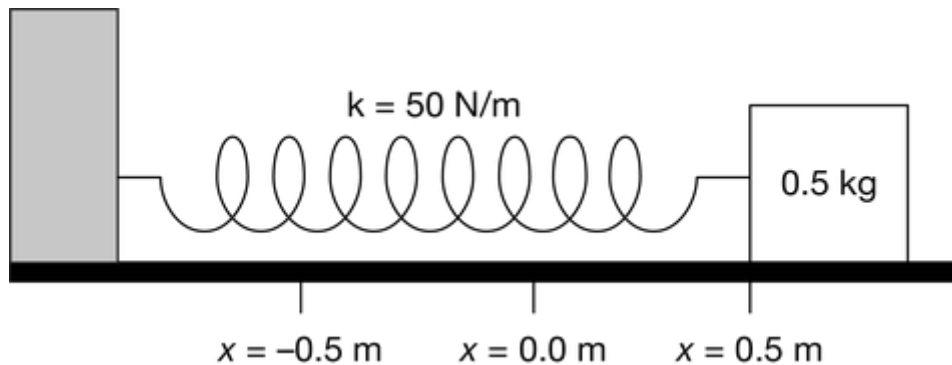

A block of mass  $0.5 \text{ kg}$  on a horizontal surface is attached to a horizontal spring of negligible mass and spring constant  $50 \text{ N/m}$ . The other end of the spring is attached to a wall, and there is negligible friction between the block and the horizontal surface. When the spring is unstretched, the block is located at  $x = 0 \text{ m}$ . The block is then pulled to  $x = 0.5 \text{ m}$  and released from rest so that the block-spring system oscillates between  $x = -0.5 \text{ m}$  and  $x = 0.5 \text{ m}$ , as shown in the figure. Which of the following claims is correct about the block's period of oscillation?

- (A) The period would increase if the block were released from rest at  $x = 0.8 \text{ m}$ .
- (B) The period would increase if the block had a mass of  $1.2 \text{ kg}$ .
- (C) The period would increase if the spring had a spring constant of  $75 \text{ N/m}$ .
- (D) The period would increase if the block-spring system was oriented vertically so that the block-spring system oscillates between  $y = -0.5 \text{ m}$  and  $y = 0.5 \text{ m}$ , the mass of the block is  $0.5 \text{ kg}$ , and the spring constant is  $50 \text{ N/m}$ .



## AP Physics-1 summer assignment

58.

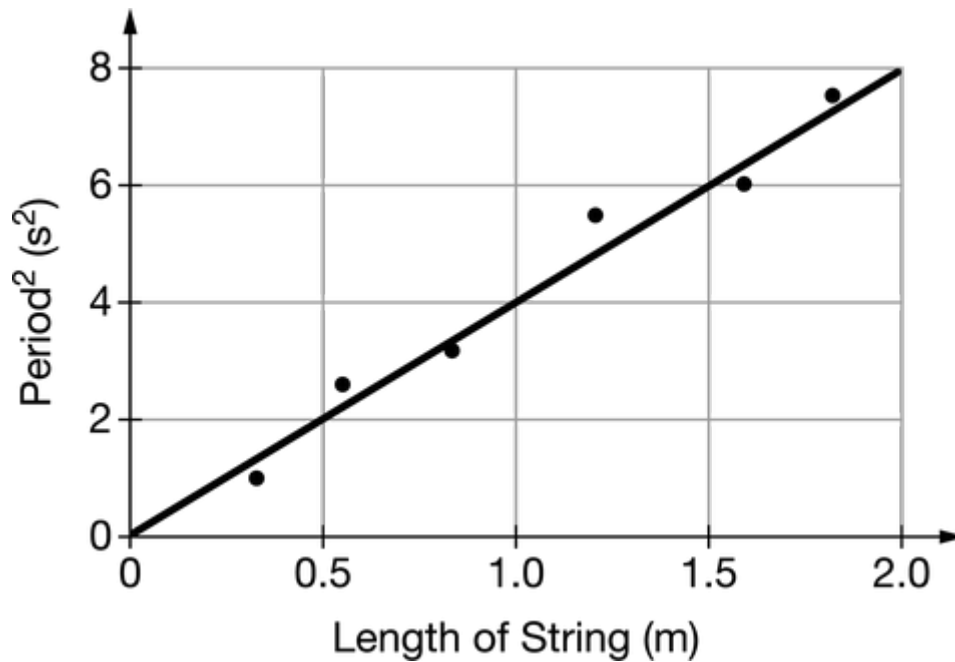

In an experiment, one end of a string is attached to an object of mass  $M$ , and the other end of the string is secured so that the object is at rest as it hangs from the string. When the object is raised to a height above its lowest point, the object undergoes simple harmonic motion. Data collected from the experiment is graphed and linearized, as shown. What information from the graph can be used to determine the acceleration due to gravity for an object that is released from rest near Earth's surface and allowed to fall to the ground?

- (A) The slope of the graph represents  $\frac{1}{\sqrt{g}}$ .
- (B) The slope of the graph represents the quantity  $\frac{2\pi}{\sqrt{g}}$ .
- (C) The slope of the graph represents the quantity  $\frac{4\pi^2}{g}$ .
- (D) The graph cannot be used to determine the acceleration due to gravity for an object that is released from rest and allowed to fall to the ground.



**AP Physics-1 summer assignment**

---

59. An object is in simple harmonic motion. Of the following quantities related to the object, which set of three can have maximum magnitudes at the same instant of time?

- I. Displacement
- II. Velocity
- III. Acceleration
- IV. Kinetic energy
- V. Potential energy

(A) I, II, and III

(B) I, II, and IV

(C) I, III, and V

(D) II, III, and IV

(E) II, III, and V

---

60. A disk of known radius and rotational inertia can rotate without friction in a horizontal plane around its fixed central axis. The disk has a cord of negligible mass wrapped around its edge. The disk is initially at rest, and the cord can be pulled to make the disk rotate. Which of the following procedures would best determine the relationship between applied torque and the resulting change in angular momentum of the disk?

(A) Pulling on the cord, exerting a force of 15 N for 2 s and then 25 N for 3 s, and measuring the final angular velocity of the disk

(B) For five different time intervals, pulling on the cord, exerting a force of 15 N, and then measuring the angle through which the disk rotates in each case

(C) For five different time intervals, pulling on the cord, exerting a force of 15 N, and then measuring the final angular velocity of the disk

(D) For five forces of different magnitude, pulling on the cord for 5 s, and then measuring the final angular velocity of the disk

---



**AP Physics-1 summer assignment**

61.

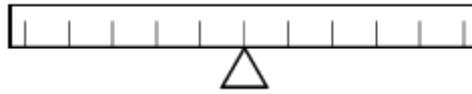

A uniform meterstick is balanced at the center, as shown above. Which of the following shows how a 0.50 kg mass and a 1.0 kg mass could be hung on the meterstick so that the stick stays balanced?

- (A) 

0.50 kg                      1.0 kg
- (B) 

0.50 kg                      1.0 kg
- (C) 

0.50 kg                      1.0 kg
- (D) 

0.50 kg                      1.0 kg
- (E) 

0.50 kg                      1.0 kg



## AP Physics-1 summer assignment

62.

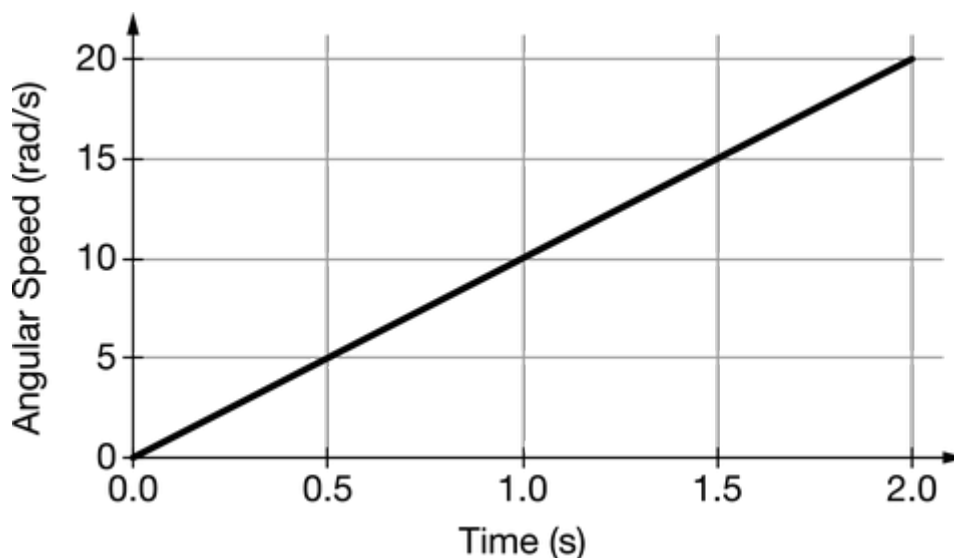

An object rotates with an angular speed that varies with time, as shown in the graph. How can the graph be used to determine the magnitude of the angular acceleration  $\alpha$  of the object? Justify your selection.

- (A) Subtract the greatest value of the angular speed from the smallest value of the angular speed, because  $\alpha = \Delta\omega$ .
- (B) Determine the slope of the line from 0 s to 2 s, because the slope represents  $\frac{\Delta\omega}{\Delta t}$ .
- (C) Determine the area bounded by the line and the horizontal axis from 0 s to 2 s, because  $\alpha = \frac{1}{2}\omega\Delta t$ .
- (D) The angular acceleration cannot be determined without knowing the rotational inertia of the object.



## AP Physics-1 summer assignment

63.

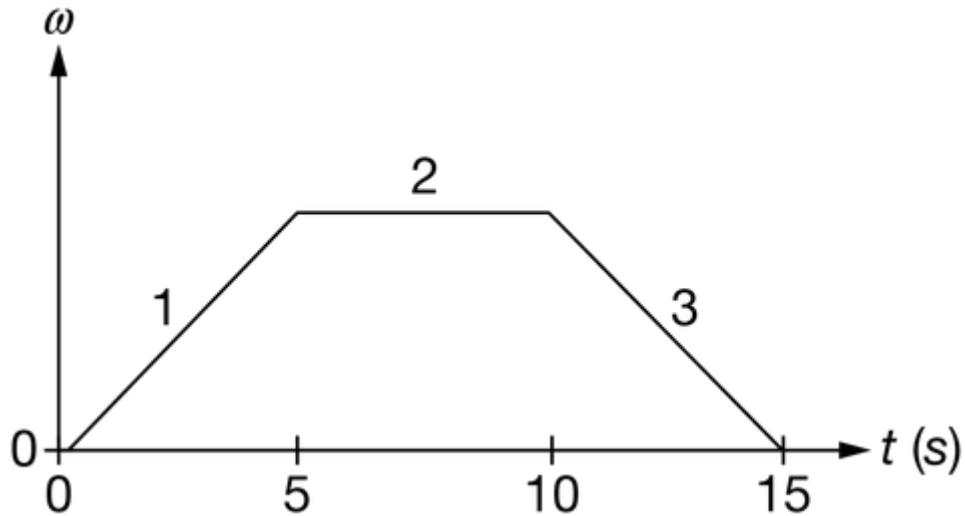

A graph of the angular velocity  $\omega$  as a function of time  $t$  is shown for an object that rotates about an axis. Three time intervals, 1–3, are shown. Which of the following correctly compares the angular displacement  $\Delta\theta$  of the object during each time interval?

- (A)  $\Delta\theta_1 = \Delta\theta_3 > \Delta\theta_2$
- (B)  $\Delta\theta_2 > \Delta\theta_1 = \Delta\theta_3$
- (C)  $\Delta\theta_3 > \Delta\theta_2 > \Delta\theta_1$
- (D)  $\Delta\theta_1 > \Delta\theta_2 > \Delta\theta_3$



## AP Physics-1 summer assignment

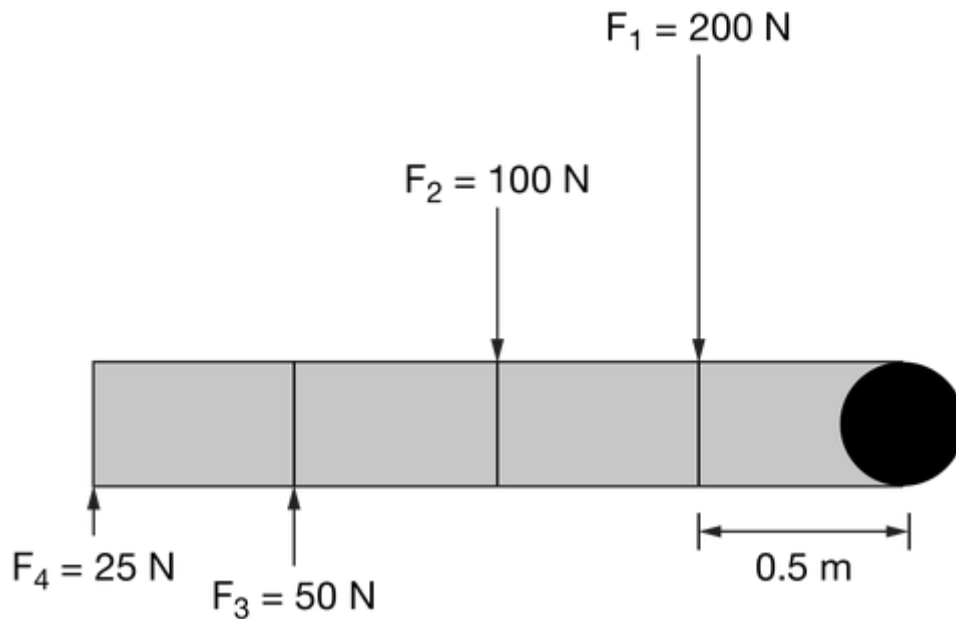

The figure above represents a stick of uniform density that is attached to a pivot at the right end and has equally spaced marks along its length. Any one or a combination of the four forces shown can be exerted on the stick as indicated.

64. All four forces are exerted on the stick that is initially at rest. What is the angular momentum of the stick after  $2.0\text{ s}$  ?

- (A)  $150 \frac{\text{kg}\cdot\text{m}^2}{\text{s}}$
- (B)  $450 \frac{\text{kg}\cdot\text{m}^2}{\text{s}}$
- (C)  $650 \frac{\text{kg}\cdot\text{m}^2}{\text{s}}$
- (D)  $750 \frac{\text{kg}\cdot\text{m}^2}{\text{s}}$





## AP Physics-1 summer assignment

65.

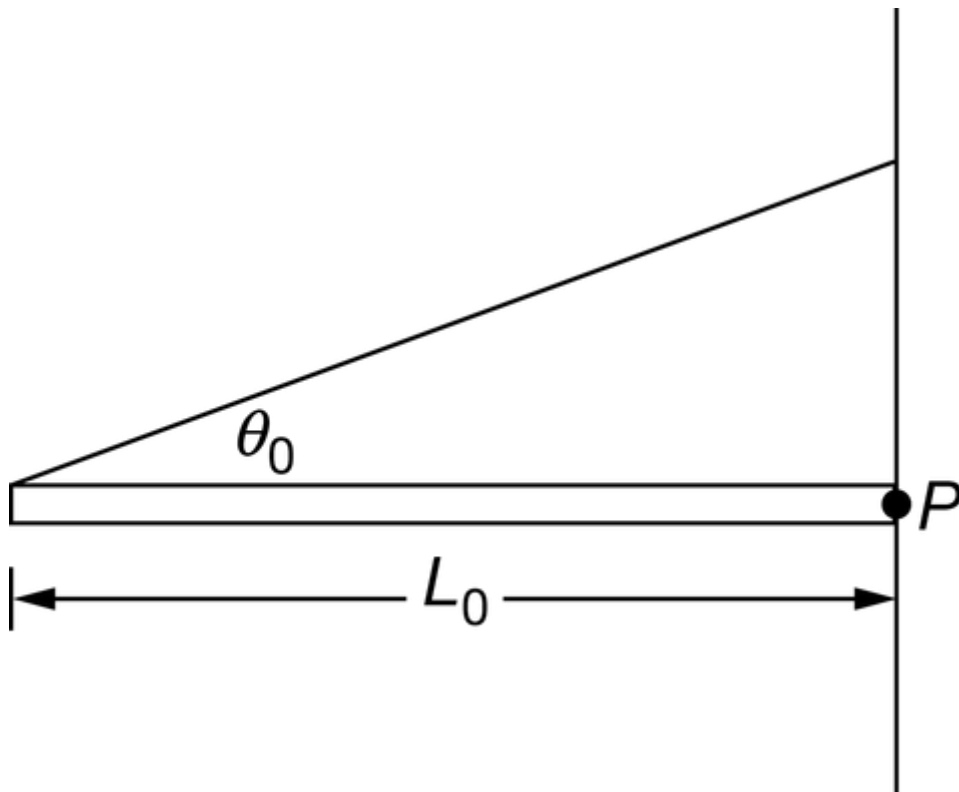

A uniform horizontal beam of mass  $M$  and length  $L_0$  is attached to a hinge at point  $P$ , with the opposite end supported by a cable, as shown in the figure. The angle between the beam and the cable is  $\theta_0$ . What is the magnitude of the torque that the cable exerts on the beam?

- (A)  $\frac{MgL_0}{2}$
- (B)  $MgL$
- (C)  $\frac{MgL_0 \sin(\theta_0)}{2}$
- (D)  $MgL_0 \sin(\theta_0)$

A horizontal, uniform board of weight 125 N and length 4 m is supported by vertical chains at each end. A person weighing 500 N is sitting on the board. The tension in the right chain is 250 N.

66. How far from the left end of the board is the person sitting?



**AP Physics-1 summer assignment**

---

- (A) 0.4 m
- (B) 1.5 m
- (C) 2 m
- (D) 2.5 m
- (E) 3 m
- 

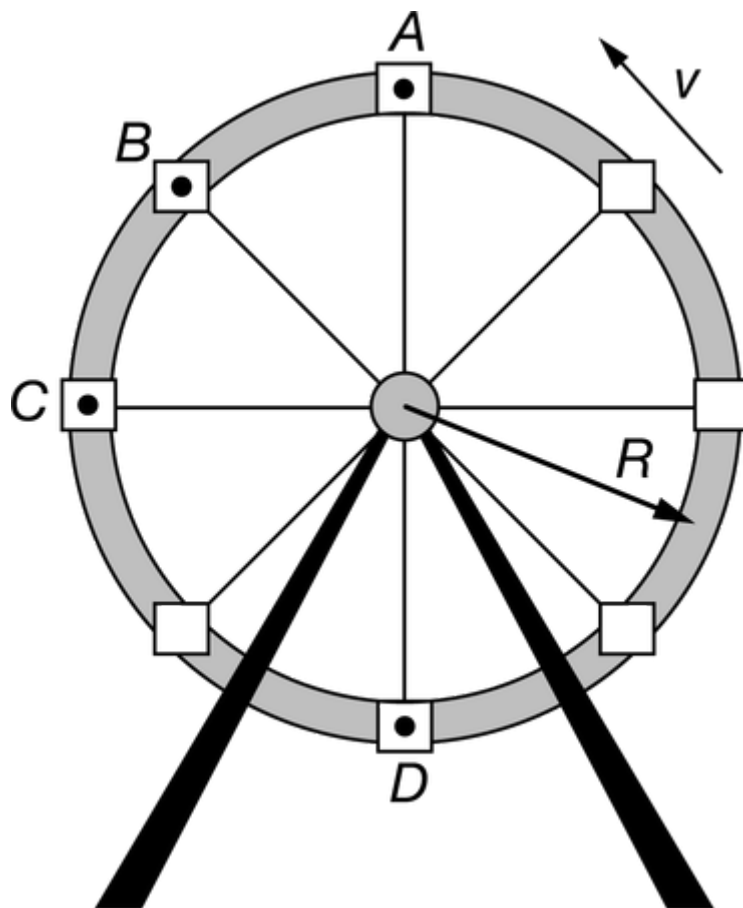

An amusement park ride consists of a large vertical wheel of radius  $R$  that rotates counterclockwise on a horizontal axis through its center, as shown above. The cars on the wheel move at a constant speed  $v$ . Points  $A$  and  $D$  represent the position of a car at the highest and lowest point of the ride, respectively. A



**AP Physics-1 summer assignment**

---

person of weight  $F_g$  sits upright on a seat in one of the cars. As the seat passes point  $A$ , the seat exerts a normal force with magnitude  $0.8F_g$  on the person. While passing point  $A$ , the person releases a small rock of mass  $m$ , which falls to the ground without hitting anything.

---

67. Which of the following best describes the passenger's linear and angular velocity while passing point  $A$  ?

Ⓐ	<b>Linear Velocity</b>	<b>Angular Velocity</b>
	Constant	Changing
Ⓑ	<b>Linear Velocity</b>	<b>Angular Velocity</b>
	Constant	Constant
Ⓒ	<b>Linear Velocity</b>	<b>Angular Velocity</b>
	Changing	Changing
Ⓓ	<b>Linear Velocity</b>	<b>Angular Velocity</b>
	Changing	Constant

---



## AP Physics-1 summer assignment

68.

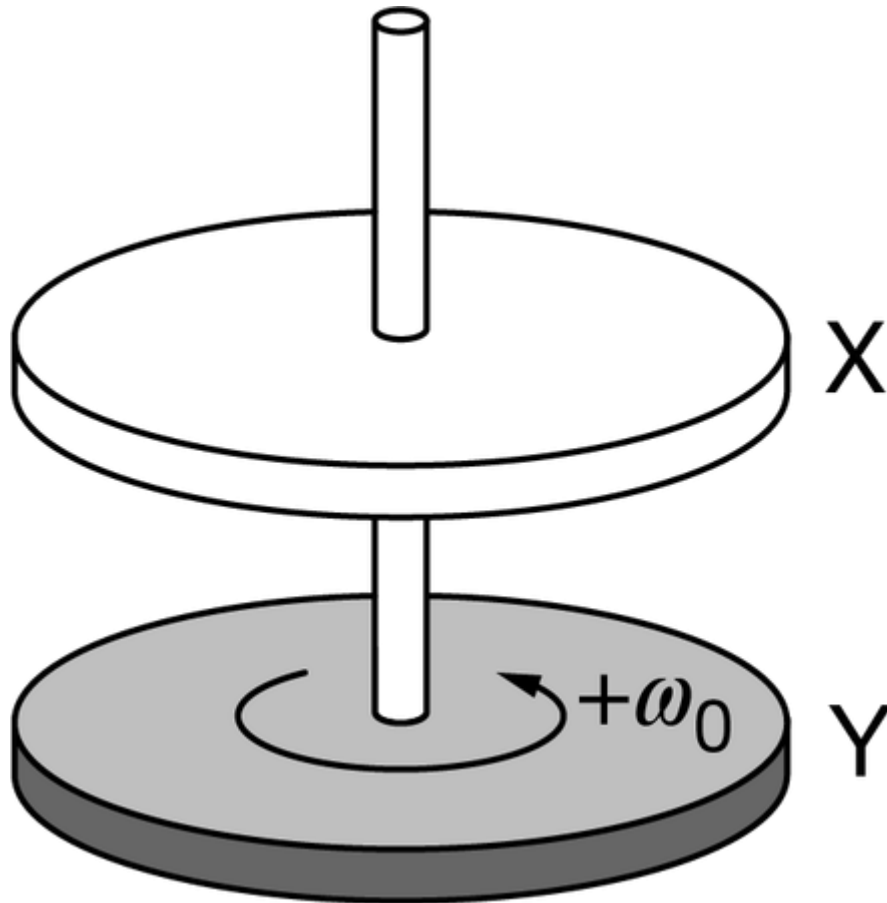

Disk **X** is held at rest above disk **Y**, which rotates with angular velocity  $+\omega_0$  about its center, as shown in the figure. Disk **Y** is slowly lowered onto disk **X** until the disks remain in contact and travel together at angular velocity  $+\omega_1$ . Which of the following linear collisions is analogous to the rotational collision that is described?

- (A) Block **X** travels toward block **Y** with velocity  $+v_1$ . Block **Y** is initially at rest. After the collision, block **Y** travels with velocity  $+v_1$ , and block **X** remains at rest.
- (B) Block **X** travels toward block **Y** with velocity  $+v_1$ . Block **Y** is initially at rest. After the collision, block **X** and block **Y** travel together with velocity  $+v_2$ .
- (C) Block **X** travels toward block **Y** with velocity  $+v_1$ . Block **Y** is initially traveling toward block **X** with velocity  $-v_1$ . After the collision, block **X** and block **Y** travel together with velocity  $+v_2$ .
- (D) Block **X** travels toward block **Y** with velocity  $+v_1$ . Block **Y** is initially traveling toward block **X** with velocity  $-v_1$ . After the collision, block **X** travels with velocity  $-v_2$  and block **Y** travels with velocity  $+v_3$ .



**AP Physics-1 summer assignment**

---

69. A wheel with radius  $0.33 \text{ m}$  and rotational inertia  $2.0 \text{ kg} \cdot \text{m}^2$  spins on an axle with an initial angular speed of  $3.0 \text{ rad/s}$ . Friction in the axle exerts a torque on the wheel, causing the wheel to stop after  $6.0 \text{ s}$ . The average torque exerted on the wheel as it slows down has magnitude

(A)  $0.50 \text{ N} \cdot \text{m}$

(B)  $1.0 \text{ N} \cdot \text{m}$

(C)  $2.0 \text{ N} \cdot \text{m}$

(D)  $3.0 \text{ N} \cdot \text{m}$

---



## AP Physics-1 summer assignment

70.

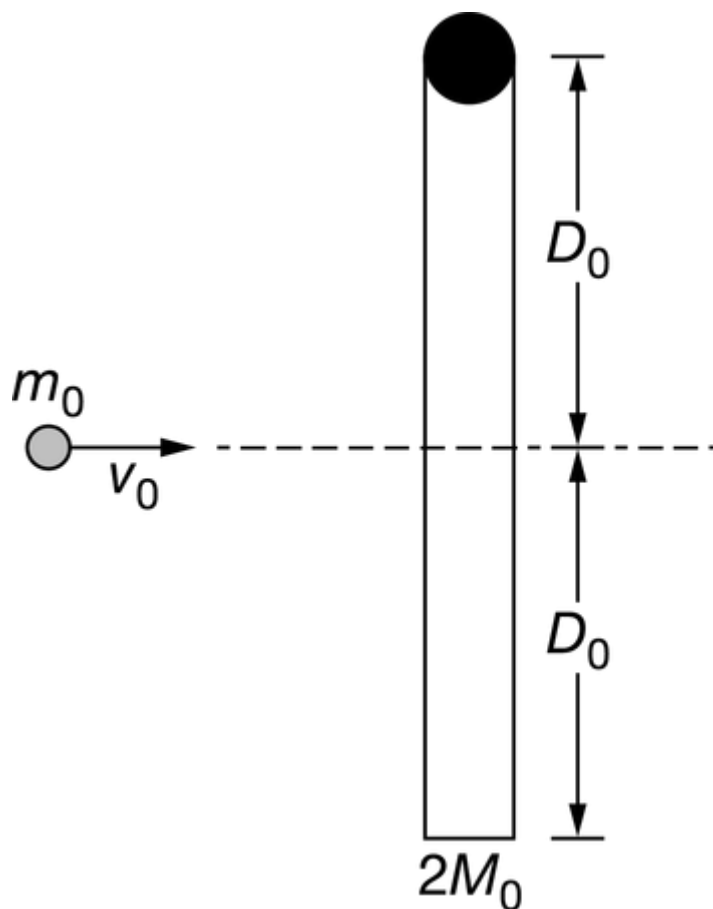

A rod of length  $2D_0$  and mass  $2M_0$  is at rest on a flat, horizontal surface. One end of the rod is connected to a pivot that the rod will rotate around if acted upon by a net torque. A lump of clay of mass  $m_0$  is launched horizontally toward the center of the rod with velocity  $v_0$ , as shown in the figure. After the clay collides with the rod, the clay sticks to the rod and both objects rotate around the pivot with the common angular velocity  $\omega_f$ . The rotational inertia of the clay-rod system is  $I_s$ . Which of the following equations could a student use to solve for the common angular velocity  $\omega_f$  immediately after the collision? Justify your selection.

- (A)  $m_0 v_0 D_0 = I_s \omega_f$ , because the clay hits the rod a distance  $D_0$  from the pivot.
- (B)  $2m_0 v_0 D_0 = I_s \omega_f$ , because the length of the rod is  $2D_0$ .
- (C)  $2M_0 v_0 D_0 = I_s \omega_f$ , because the rod's mass is  $2M_0$  and the clay hits the rod a distance  $D_0$  from the pivot.
- (D)  $4M_0 v_0 D_0 = I_s \omega_f$ , because the rod's mass is  $2M_0$  and its length is  $2D_0$ .



**AP Physics-1 summer assignment**

---

71. A charged sphere located at the origin of the  $xy$ -plane exerts a force of magnitude  $F$  on a charged particle located at  $(+d, 0)$ . The sphere will exert a force  $F/2$  on the particle if the particle is moved to which of the following locations?

- (A)  $(+2d, 0)$
- (B)  $(+d, +d)$
- (C)  $(+d/2, 0)$
- (D)  $(0, -d)$
- 

72.

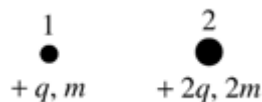

An isolated system consists of the two particles shown above. Particle 1 has charge  $+q$  and mass  $m$ . Particle 2 has charge  $+2q$  and mass  $2m$ . The ratio of the magnitude of the electrical force on particle 1 to the magnitude of the electrical force on particle 2 is

- (A)  $\frac{1}{4}$
- (B)  $\frac{1}{2}$
- (C) 1
- (D) 2
- (E) 4
- 

A student is provided with a rubber cylinder and a patch of synthetic fur. The rubber cylinder and the



## AP Physics-1 summer assignment

---

patch are electrically neutral. The student rubs the cylinder back and forth along the fur. A short time later, after the cylinder and fur have been placed on insulating stands, the student determines that the fur has a net negative electric charge.

---

73. Which of the following claims is correct about the net charge of the rubber cylinder after it has been rubbed on the patch of fur?
- (A) It has a net positive charge.
  - (B) It has a net negative charge.
  - (C) It has a net neutral charge.
  - (D) The answer cannot be determined without knowing more information about the charging process used to charge the patch of fur.
- 
74. A scientist conducts an experiment to determine the net charge of small object. After the experiment is conducted ten times, the scientist claims that the charge of the object is  $(5.6 \times 10^{-19} \pm 0.1) \text{ C}$ . Which of the following claims, with appropriate evidence, is correct about the charge of the object? Justify your selection.
- (A) The charge of the object must be correct, because the experiment was conducted for ten trials and the same result was determined.
  - (B) The charge of the object must be correct, because the uncertainty of the measurement is less than 2%.
  - (C) The charge of the object must not be correct, because the charge of any object must be a whole number within experimental uncertainty.
  - (D) The charge of the object must not be correct, because a fraction of an elementary charge does not exist.
- 
75. An object of mass  $1.0 \times 10^{10} \text{ kg}$  and charge  $+0.86 \text{ C}$  is separated by a distance of  $10,000 \text{ m}$  from another object of mass  $1.0 \times 10^{10} \text{ kg}$  and charge  $+0.86 \text{ C}$ . Which of the following claims is correct about the electric force and the gravitational force exerted on one object from the other object?





**AP Physics-1 summer assignment**

---

- (A) The gravitational force is attractive, and the electric force is repulsive. The electric force has nearly the same magnitude as the gravitational force.
- (B) The gravitational force is attractive, and the electric force is repulsive. The electric force is significantly greater in magnitude than the gravitational force.
- (C) The gravitational force is attractive, and the electric force is repulsive. The electric force is significantly smaller in magnitude than the gravitational force.
- (D) There are no differences between the two forces.
- 

76. If the charge of each of two particles is doubled and the separation between them is also doubled, the force between the two particles is

- (A) quadrupled
- (B) doubled
- (C) the same as before
- (D) halved
- (E) quartered
- 



## AP Physics-1 summer assignment

77.

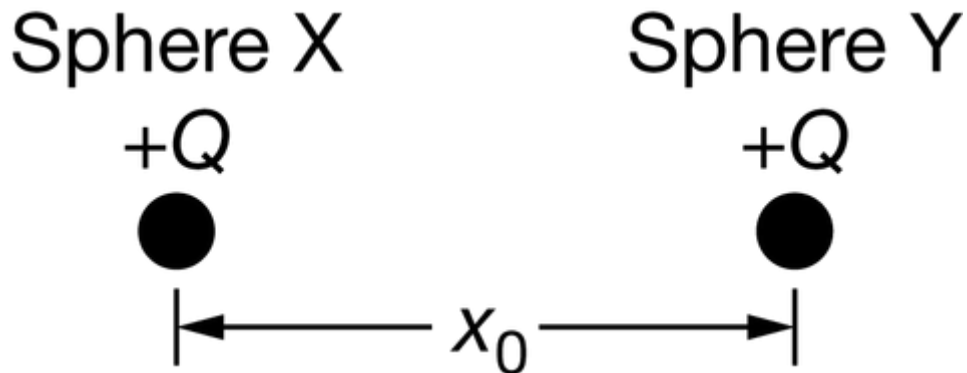

Spheres X and Y of charge  $+Q$  are separated by a distance  $x_0$ , as shown in the figure. The force exerted on sphere X from sphere Y is  $F_0$ . The charge of sphere X is then increased to  $+9Q$ . What new separation distance between the spheres would result in an electric force  $F_0$  that is exerted on sphere X from sphere Y?

- (A)  $\frac{x_0}{3}$
- (B)  $\frac{x_0}{9}$
- (C)  $3x_0$
- (D)  $9x_0$

78.

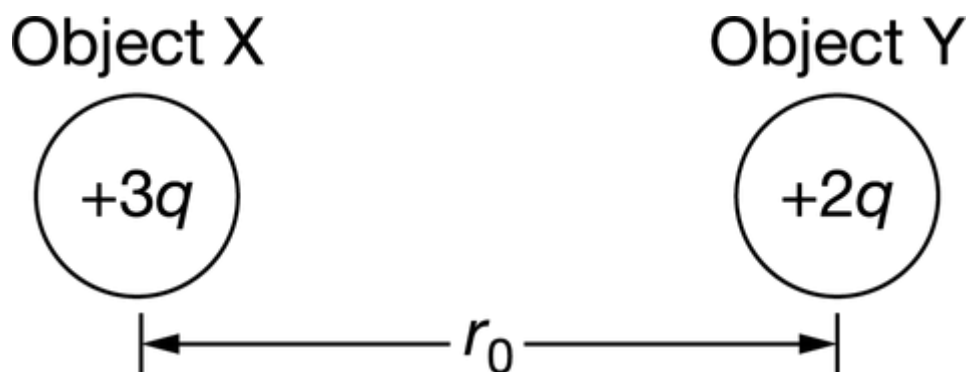

The figure shows object X and object Y that are separated by a distance  $r_0$ . The charge of each object is shown. The force exerted on object X from object Y is  $F_0$ . Which of the following predictions is correct about the magnitude of the force that object X exerts on object Y if the charge of object Y is decreased by a factor of 2 and the separation distance is decreased by a factor of 2?



**AP Physics-1 summer assignment**

---

- (A) The electric force will now be  $\frac{3F_0}{4}$ .
- (B) The electric force will now be  $\frac{3F_0}{2}$ .
- (C) The electric force will now be  $2F_0$ .
- (D) The electric force will now be  $4F_0$ .
- 

79.

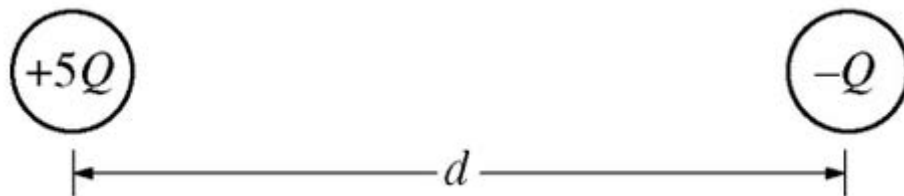

Two charged conducting spheres are separated by a distance  $d$ , as shown in the figure above. One sphere has charge  $+5Q$ , the other has charge  $-Q$ , and the diameter of each sphere is much smaller than  $d$ . Each sphere exerts a force of magnitude  $F$  on the other. The spheres are brought together and touch briefly. After touching, the left sphere has charge  $+2Q$ . The spheres are then returned to their original locations. What is the magnitude of the new force between the spheres?

- (A)  $\frac{2}{5} F$
- (B)  $\frac{4}{5} F$
- (C)  $\frac{9}{5} F$
- (D)  $4F$
- 



## AP Physics-1 summer assignment

80.

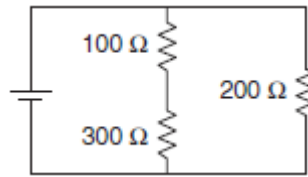

The figure above shows three resistors connected in a circuit with a battery. Which of the following correctly ranks the energy  $E$  dissipated in the three resistors during a given time interval?

- (A)  $E_{300\Omega} > E_{200\Omega} > E_{100\Omega}$
- (B)  $E_{300\Omega} > E_{100\Omega} > E_{200\Omega}$
- (C)  $E_{200\Omega} > E_{300\Omega} > E_{100\Omega}$
- (D)  $E_{200\Omega} > E_{100\Omega} > E_{300\Omega}$

81.

Circuit Element	Potential Difference (V)	Current (A)
Battery	10	8
Resistor $R_1$	6	8
Resistor $R_2$	4	3
Resistor $R_3$	4	5

The above table shows the potential difference and current for each circuit element in a circuit consisting of a battery and three resistors. Which of the following diagrams could represent the circuit?



AP Physics-1 summer assignment

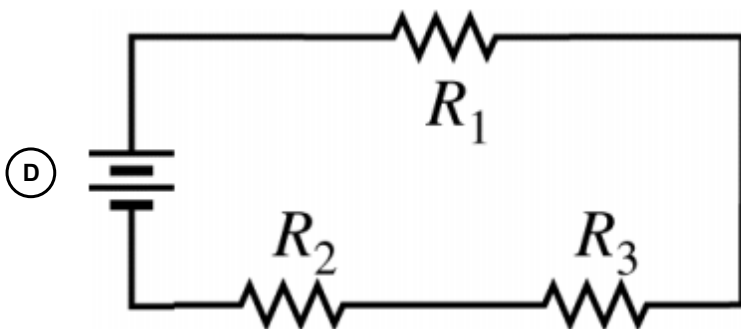
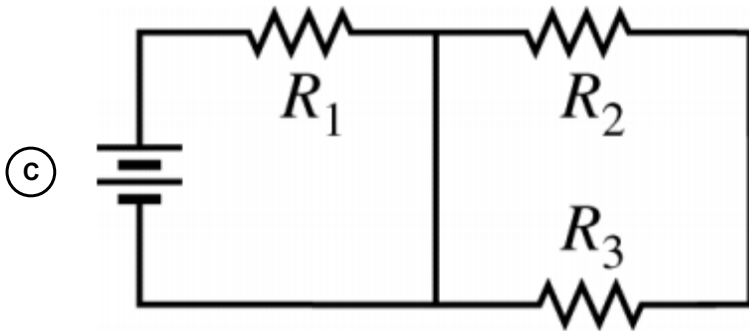
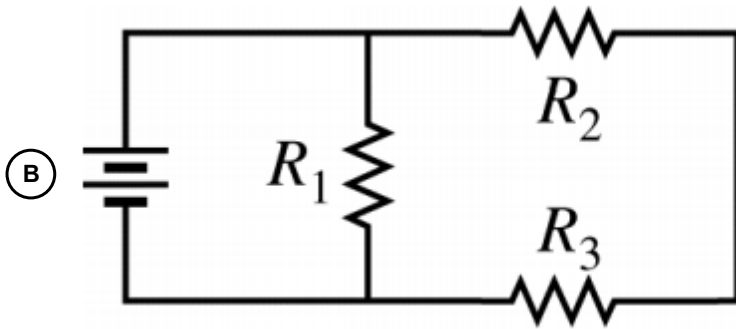
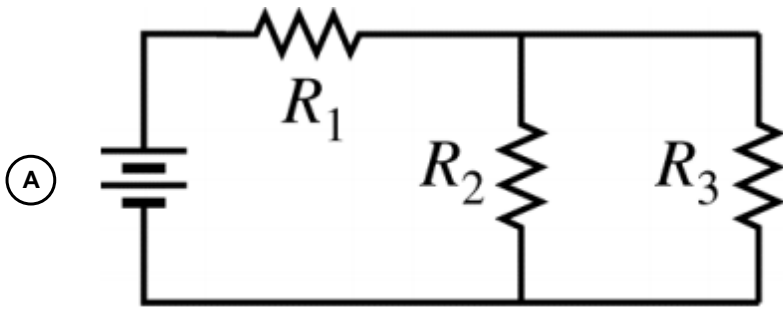

## AP Physics-1 summer assignment

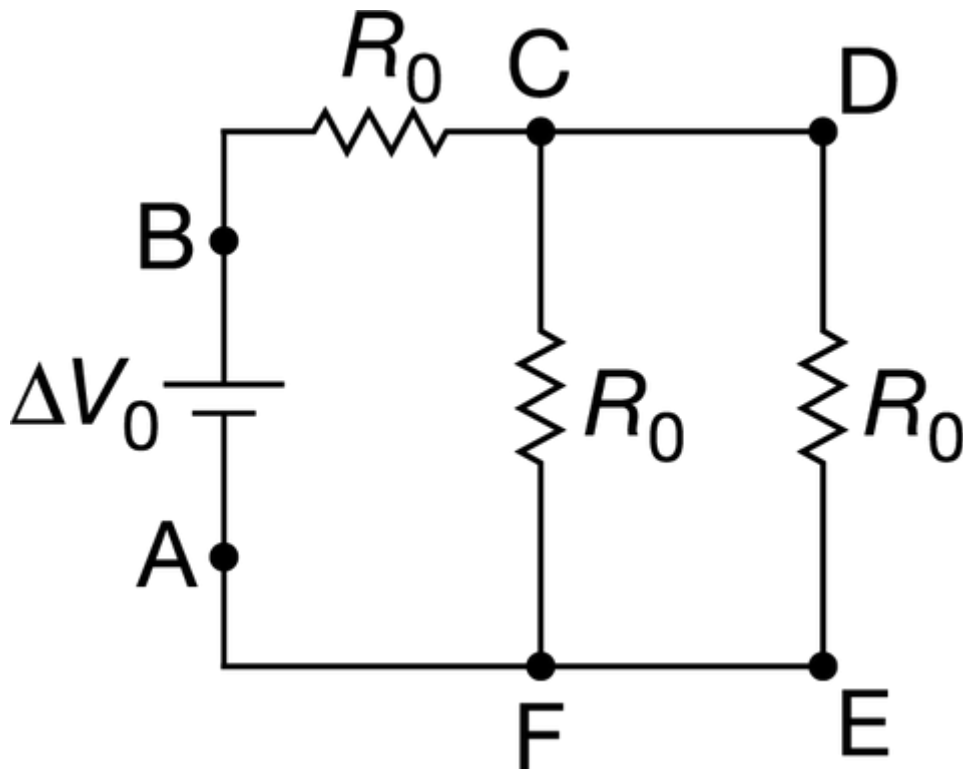

Three resistors of known resistance  $R_0$  are arranged in the circuit that is shown. The potential difference across the battery is  $\Delta V_0$ .

82. The current at point E is  $I_0$ . What is the current that flows through point A?

- (A) Zero
- (B)  $\frac{I_0}{2}$
- (C)  $I_0$
- (D)  $2I_0$



AP Physics-1 summer assignment

---

83.

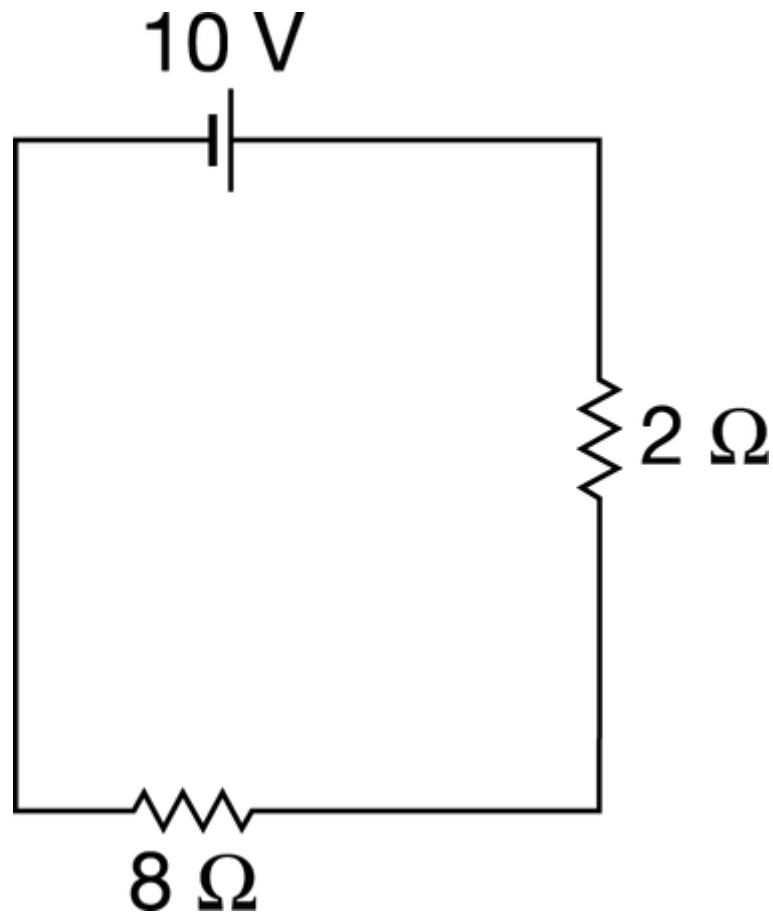

A student creates a circuit that consists of a single battery and two resistors that are arranged as shown in the figure. What is the current that passes through the  $2\ \Omega$  resistor?

- (A)  $0.5\text{ A}$
- (B)  $1\text{ A}$
- (C)  $1.25\text{ A}$
- (D)  $5\text{ A}$
- 



## AP Physics-1 summer assignment

84.

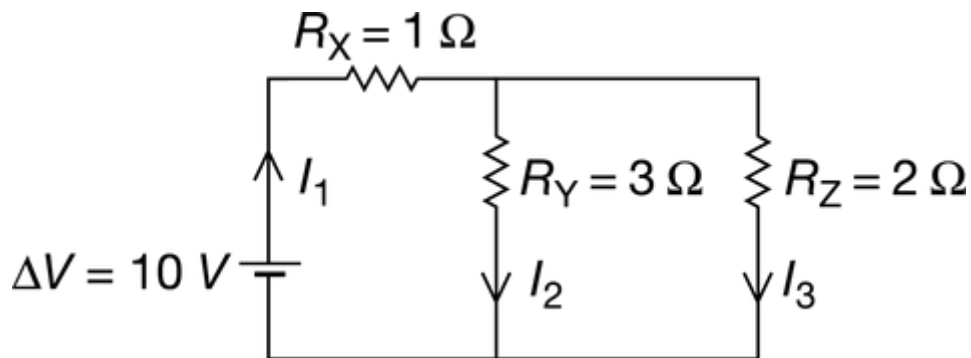

A circuit consists of a single battery and three resistors. Current flows from the battery and splits at the junction, as shown in the diagram. Which two of the following claims is true regarding the circuit? Select two answers.

- (A)  $I_2$  is larger than  $I_3$ .
- (B) Increasing the resistance of  $R_X$  will increase  $I_3$ .
- (C) 10 V is the sum of  $\Delta V_X$  and  $\Delta V_Z$ .
- (D)  $\Delta V_Y$  is the same as  $\Delta V_Z$ .

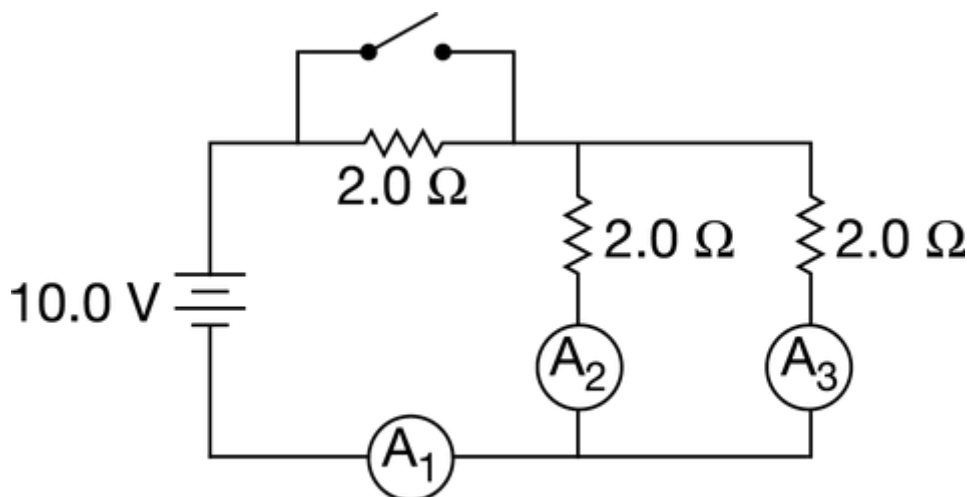

Figure 1. When the switch is open





## AP Physics-1 summer assignment

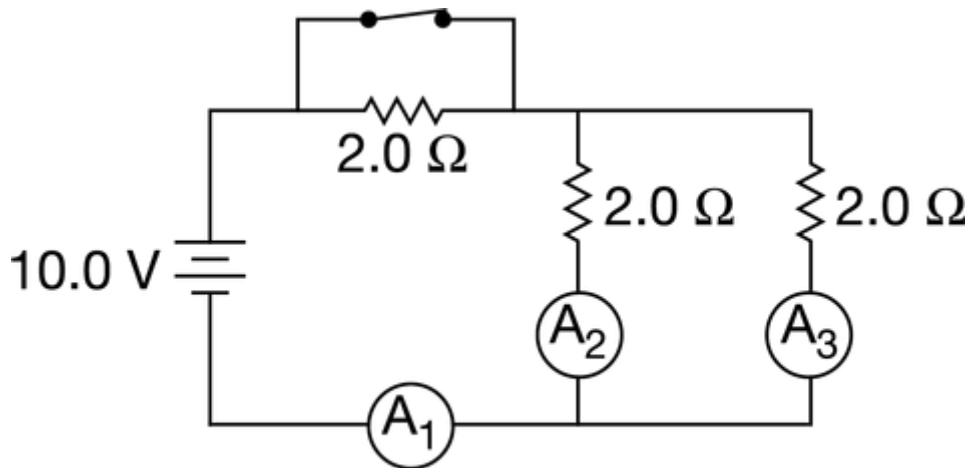

Figure 2. When the switch is closed

A student creates a circuit that consists of a single battery, three resistors, and a switch that are arranged as shown. Figure 1 shows the circuit when the switch is open and Figure 2 shows the circuit when the switch is closed. The student places three ammeters,  $A_1$ ,  $A_2$ , and  $A_3$ , in different locations to measure the current flowing through the circuit at those locations.

85. Which of the following claims is correct about how  $\Delta V_3$ , the potential difference across the resistor connected to  $A_3$ , changes when the switch is closed?
- (A) The potential difference  $\Delta V_3$  is greater when the switch is closed, as in Figure 2.
- (B) The potential difference  $\Delta V_3$  is greater when the switch is open, as in Figure 1.
- (C) The potential difference  $\Delta V_3$  is the same when the switch is open as when the switch is closed.
- (D) A comparison cannot be made without knowing the total current in each circuit.



**AP Physics-1 summer assignment**

---

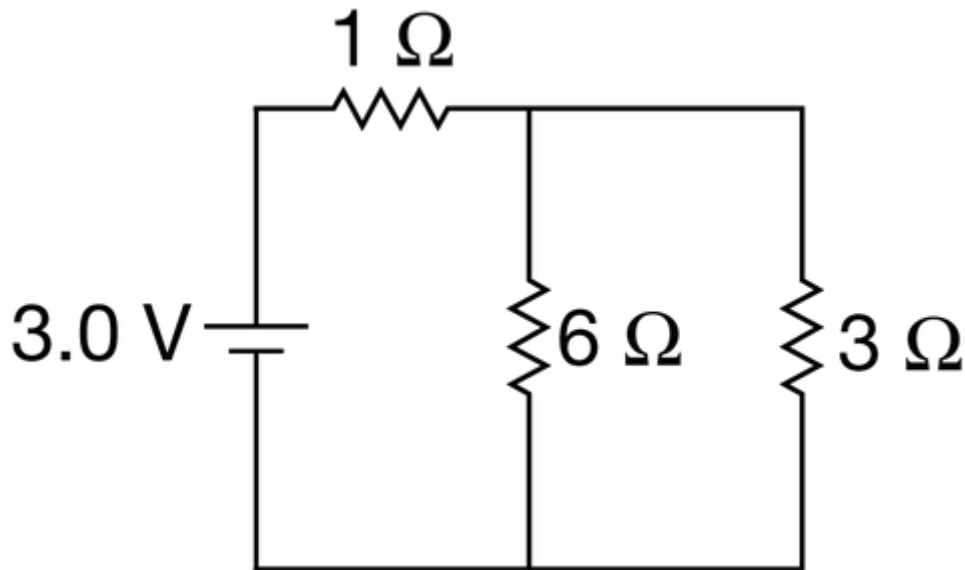

A student creates a circuit that consists of a single battery and three resistors that are arranged as shown. The battery supplies a total current of 1 A.

86. The battery connected to the circuit is changed such that the total current that flows out of the battery is now 2 A. Which of the following claims is correct regarding how much charge flows into the battery after the current is allowed to flow for 60 s?
- (A) Less than 120 C
  - (B) Exactly 120 C
  - (C) More than 120 C
  - (D) The answer cannot be determined without knowing the new potential difference for the battery.



## AP Physics-1 summer assignment

87.

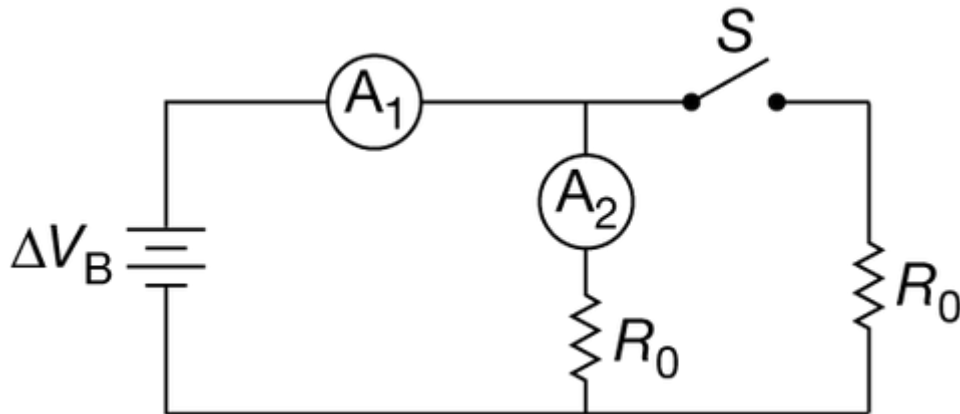

Battery  $V_B$ , switch  $S$ , two ammeters,  $A_1$  and  $A_2$ , and two identical resistors of resistance  $R_0$  are arranged in the circuit that is shown. Current  $I_0$  flows through ammeters when the switch  $S$  is open. Which of the following correctly predicts the current in the ammeters when the switch is closed?

- (A) The current through ammeter  $A_1$  would be  $2 I_0$ .
- (B) The current through ammeter  $A_1$  would be  $I_0$ .
- (C) The current through ammeter  $A_1$  and ammeter  $A_2$  would be  $I_0$ .
- (D) The current through ammeter  $A_1$  would be  $\frac{1}{2} I_0$ .



## AP Physics-1 summer assignment

88.

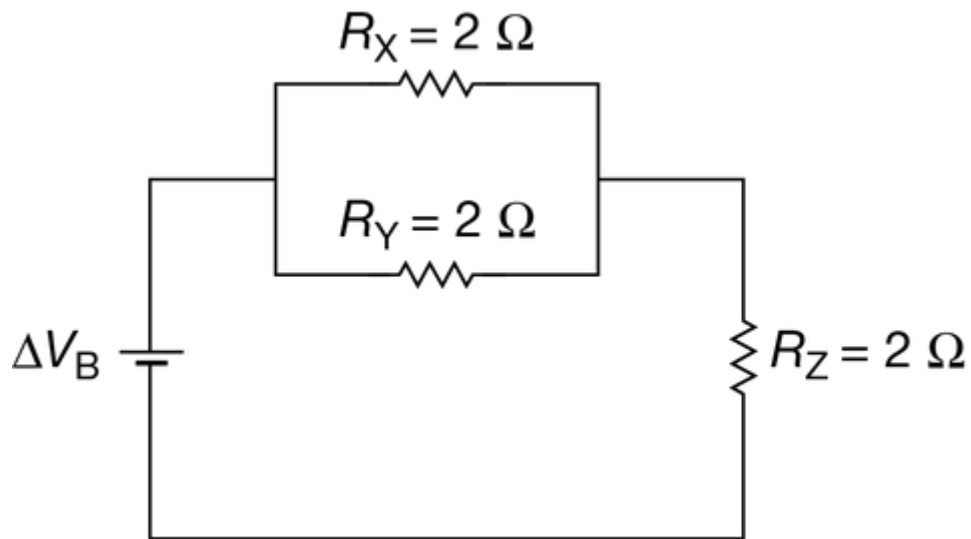

A circuit consists of a single battery and three resistors that are arranged as shown. How does the power  $P_z$  dissipated by resistor  $R_z$  compare to the power  $P_y$  dissipated by resistor  $R_y$ ?

- (A)  $\Delta P_z = \frac{\Delta P_y}{2}$
- (B)  $\Delta P_z = \Delta P_y$
- (C)  $\Delta P_z = 2 P_y$
- (D)  $\Delta P_z = 4\Delta P_y$



## AP Physics-1 summer assignment

89.

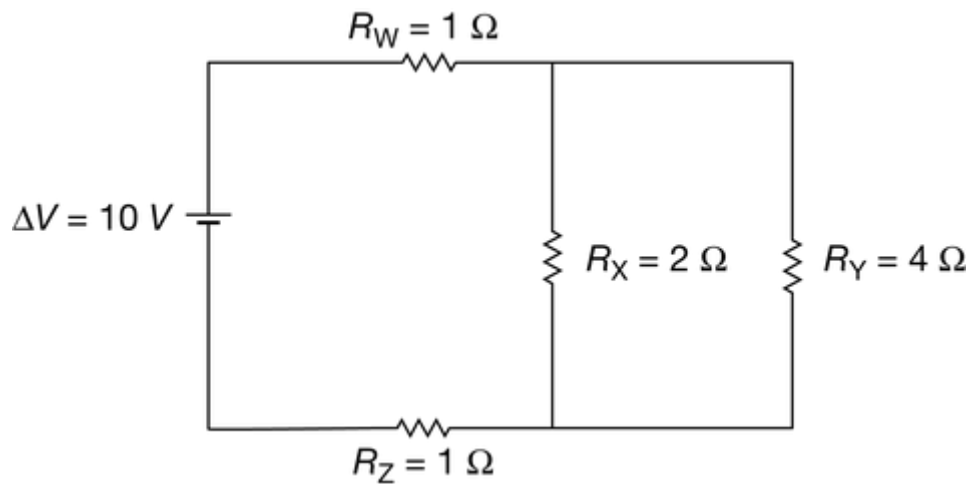

A circuit consists of a single battery and four resistors that are arranged as shown. The amount of electromagnetic energy that is converted into nonmechanical energy after 10 s for  $R_W$  is most nearly

- (A) 40 J
- (B) 80 J
- (C) 90 J
- (D) 300 J

The following questions relate to the circuit diagram below.



## AP Physics-1 summer assignment

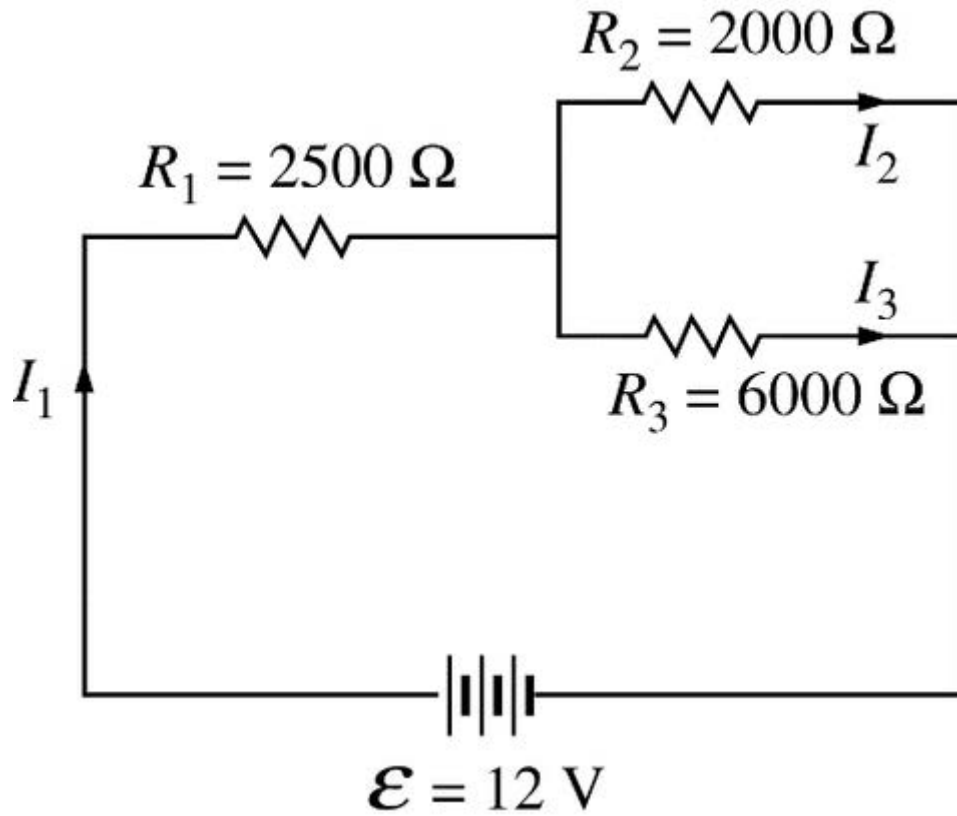

90. How do the currents  $I_1$ ,  $I_2$ , and  $I_3$  compare?

- (A)  $I_1 > I_2 > I_3$
- (B)  $I_1 > I_3 > I_2$
- (C)  $I_2 > I_1 > I_3$
- (D)  $I_3 > I_1 > I_2$
- (E)  $I_3 > I_2 > I_1$



## AP Physics-1 summer assignment

91.

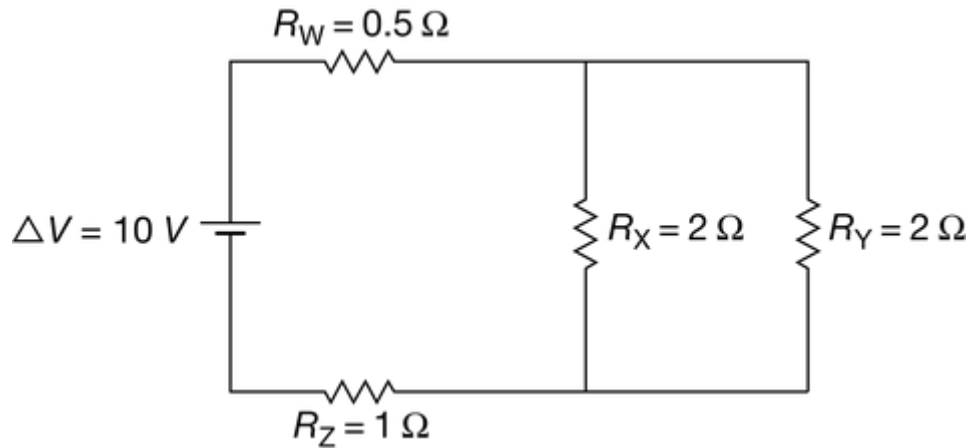

A circuit that consists of a single battery and four resistors are arranged as shown in the figure. Which of the following quantities correctly describe the circuit? Select two answers.

- (A) The equivalent resistance of the circuit is  $3.5\ \Omega$ .
- (B) The power dissipated by resistor  $R_Y$  is  $8\ \frac{\text{J}}{\text{s}}$ .
- (C) The potential difference across resistor  $R_X$  is  $2\ \text{V}$ .
- (D) The total current that flows through the circuit is  $4\ \text{A}$ .



## AP Physics-1 summer assignment

92.

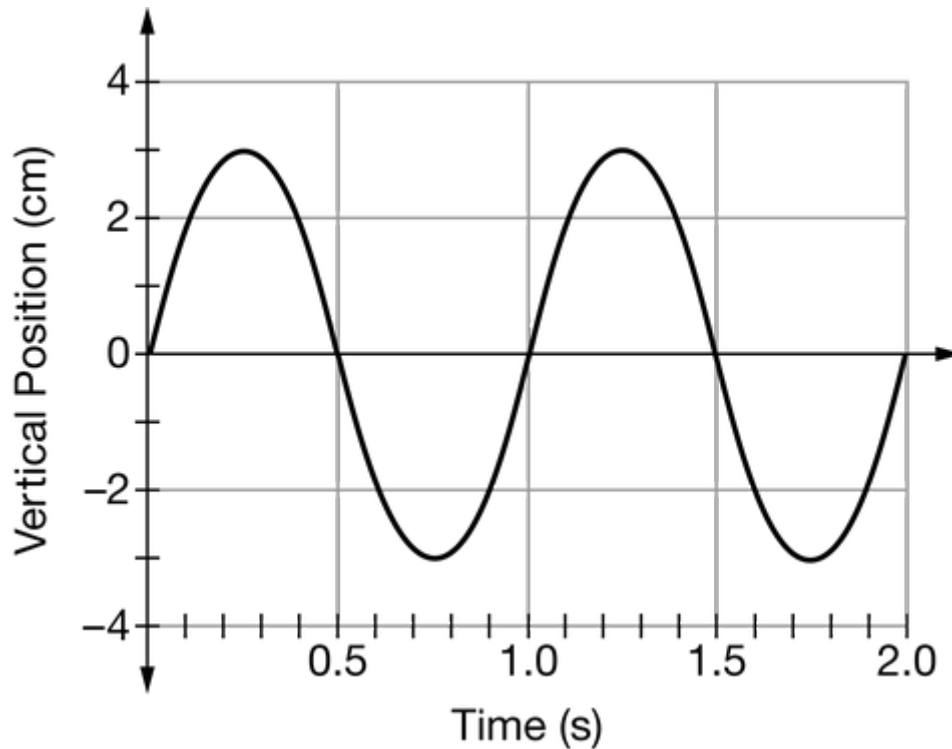

A transverse periodic wave travels along a string that is stretched along the horizontal axis. The graph shows the vertical position of a particle on the string as a function of time. What is the amplitude of the wave?

- (A) 1.0 cm
- (B) 1.5 cm
- (C) 3.0 cm
- (D) 6.0 cm

93. An organ pipe of length  $L$  is open at one end and closed at the other. The standing wave of next-to-lowest frequency which can exist in this pipe has a wavelength nearest to





**AP Physics-1 summer assignment**

---

(A)  $\frac{1}{3} L$

(B)  $\frac{1}{2} L$

(C)  $L$

(D)  $\frac{4}{3} L$

(E)  $2 L$

---

94. At a point of observation, the time between successive crests of a passing wave is 0.2 s. Which of the following must be true of the wave?

(A) Its wavelength is 0.2 m.

(B) Its wavelength is 5 m.

(C) Its period is 5 s.

(D) Its frequency is 5 Hz.

(E) Its velocity of propagation is 5 m/s.

---



**AP Physics-1 summer assignment**

---

95.

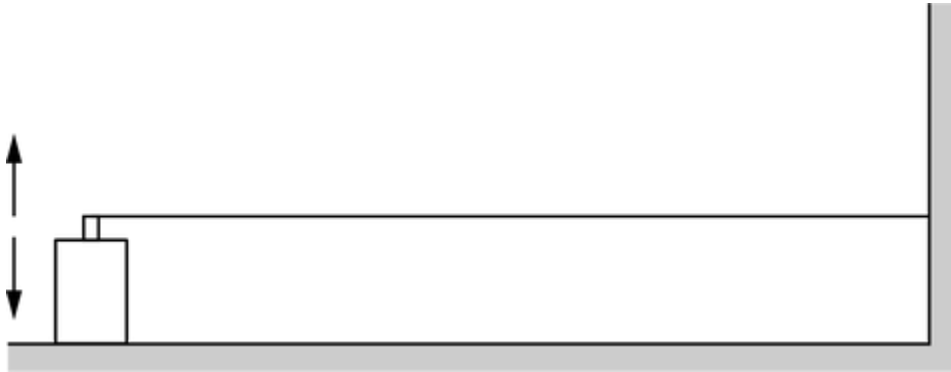

One end of a horizontal string is secured to the wall, and the other end is connected to a device that can send wave pulses through the string by vibrating up and down, as shown in the figure. When the device is turned on, which of the following explanations is correct about the resulting wave that travels through the string?

- (A) The wave is longitudinal, because the wave moves in a direction that is parallel to the orientation of the spring.
  - (B) The wave is longitudinal, because the wave moves in a direction that is perpendicular to the orientation of the spring.
  - (C) The wave is transverse, because the wave moves in a direction that is parallel to the orientation of the spring.
  - (D) The wave is transverse, because the wave moves in a direction that is perpendicular to the orientation of the spring.
- 



## AP Physics-1 summer assignment

96.

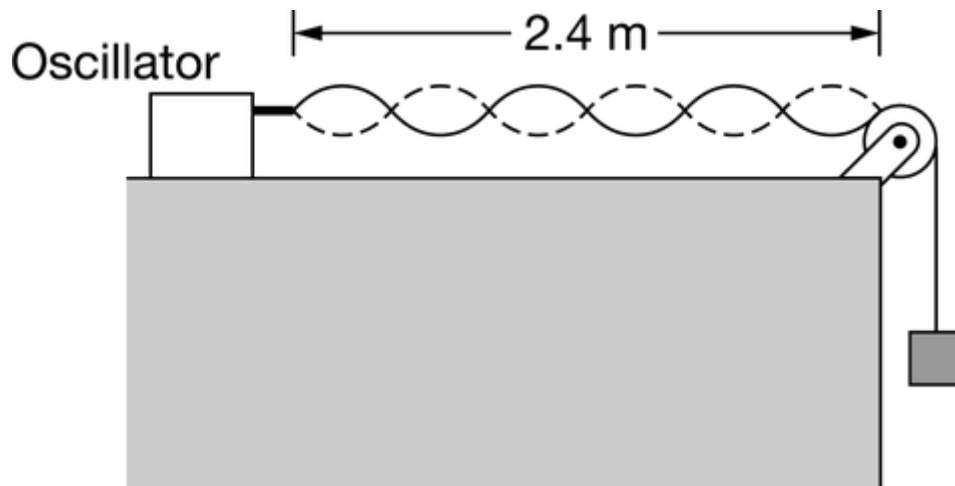

One end of a string is attached to an oscillator, and the other end passes over a pulley and is connected to a hanging block. The oscillator can be adjusted to form different patterns of standing waves in the string. The students adjust the oscillator so that it makes the standing wave that is shown in the figure. The oscillator vibrates at a frequency of  $25.0 \text{ Hz}$ , producing a standing wave pattern in a  $2.4 \text{ m}$  long string, as shown in the figure. The fundamental frequency for a standing wave is  $4.17 \text{ Hz}$ . The frequency is then increased to  $27.0 \text{ Hz}$ . Which of the following claims is correct about how the change will affect the resulting wave on the string?

- (A) A new standing wave will have seven antinodes.
- (B) The wavelength of a new standing wave will be nearly  $0.74 \text{ m}$ .
- (C) A new standing wave will propagate faster through the string.
- (D) A standing wave will not be produced.

97. A guitar string with length  $0.80 \text{ m}$  resonates at a fundamental frequency of  $320 \text{ Hz}$ . A person presses on the string so that its effective length is reduced to  $0.65 \text{ m}$ , but the tension in the string does not change. The fundamental frequency of the  $0.65 \text{ m}$  string is most nearly



**AP Physics-1 summer assignment**

---

- (A) 260 Hz
- (B) 320 Hz
- (C) 390 Hz
- (D) 530 Hz
- 

98.

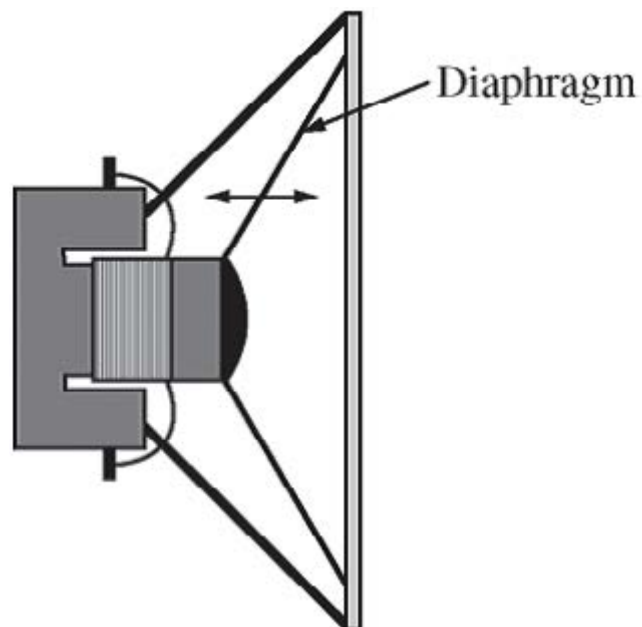

A radio speaker produces sound when a membrane called a diaphragm vibrates, as shown above. A person turns up the volume on the radio. Which of the following aspects of the motion of a point on the diaphragm must increase?



**AP Physics-1 summer assignment**

---

- (A) The maximum displacement only
- (B) The average speed only
- (C) Both the maximum displacement and the average speed
- (D) Neither the maximum displacement nor the average speed
- 

99. The frequencies of the first two overtones (second and third harmonics) of a vibrating string are  $f$  and  $3f/2$ . What is the fundamental frequency of this string?

- (A)  $f/3$
- (B)  $f/2$
- (C)  $f$
- (D)  $2f$
- (E)  $3f$
- 

100. Two tuning forks with which of the following pairs of frequencies will produce the greatest frequency of beats when sounded together?



**AP Physics-1 summer assignment**

---

- (A) 250 and 256 Hz
  - (B) 300 and 303 Hz
  - (C) 634 and 639 Hz
  - (D) 763 and 764 Hz
  - (E) 1420 and 1422 Hz
-